

Connecting Light Tape[®]

The entire rear electrode of Light Tape[®] is conductive. Unlike other antiquated technologies, you can make a connection anywhere and Light Tape[®] will illuminate evenly. No need to worry about the electrode detaching from the Light Tape[®]. ***Please see the connection video on our website or download our step by step instruction.**

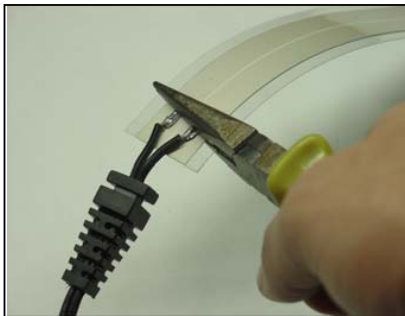

Pierce the rear (grey side with white line) of the Light Tape[®] with one connector pin on each side of the white line to create contact and electrical connection.



Fit connector caps to strain relief and prepare adhesive to completely seal connection. For outdoor applications, apply Star Brite™ to the connection.



Firmly squeeze connector caps onto strain relief (we recommend with vise grips) and complete with two locking screws.

Connector and Protective Cover Profiles

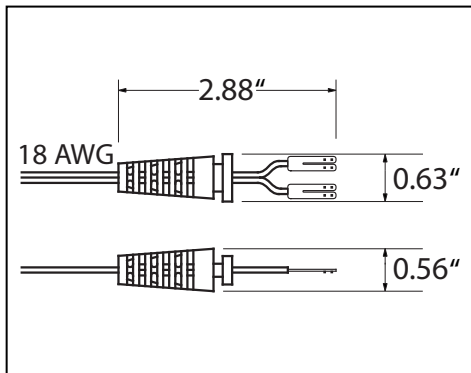

Heavy Duty Connector

- Easy two part system (as shown above)
- Designed for the highest IP enclosure rating possible.
- Water resistant
- Indoor/Outdoor

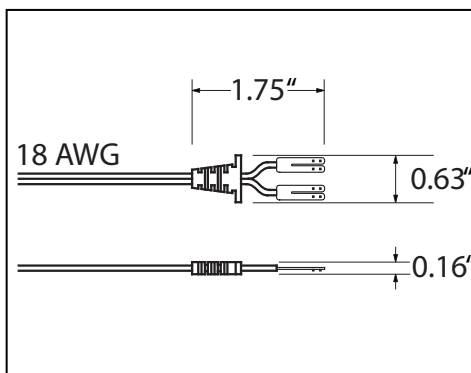
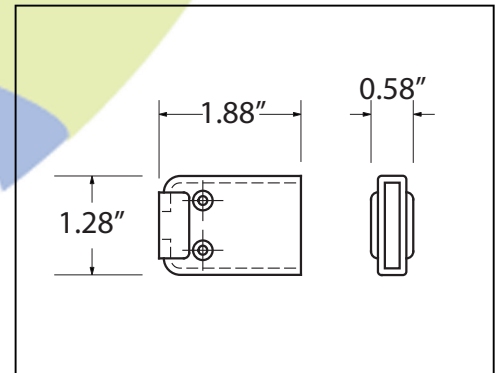

Light Duty Connector

- Lower profile and less bulky
- Indoor
- Polycarbonate caps with protective insulation

