

Floor Installation

Light Tape[®] has tremendous impact resistance properties which makes it difficult to damage. However, it is important to protect Light Tape[®] from abrasion, which can damage the barrier lamination.

Permanent Flush Mount

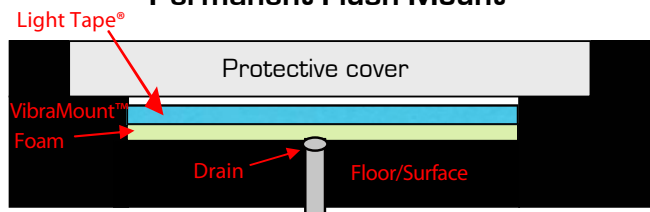

Ideally, floor is designed with channels to place Light Tape[®]. A protective cover, which can be made of glass, polycarbonate, etc., should be sealed around the edge to prevent moisture from entering. Factory sealed exterior lamination and exterior connections are required to protect the Light Tape[®]. Drain may be required in wet environments.

Permanent Flush Mount with Mounting Channel

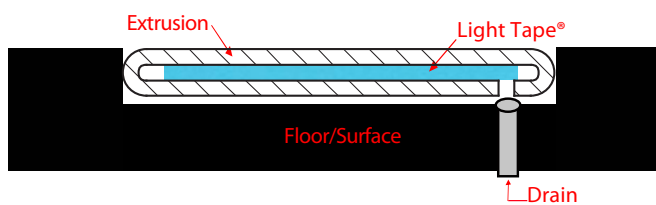

Light Tape[®] Mounting Channel is placed in prepared track which should be sloped slightly to allow for drainage. Factory sealed exterior lamination and exterior connections are necessary.

Temporary Mount

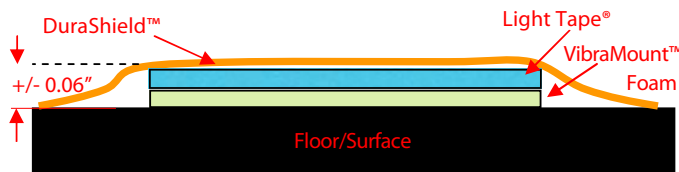

Light Tape[®] may be placed on smooth surfaces and then covered with our DuraShield™ to protect the product from general foot traffic. Rougher surfaces may require VibraMount™ foam for impact resistance. Again, factory sealed exterior lamination and exterior connections are required.

Create Your Own Backlit System

It is possible to construct your own light box or mounting channel for larger format installations.

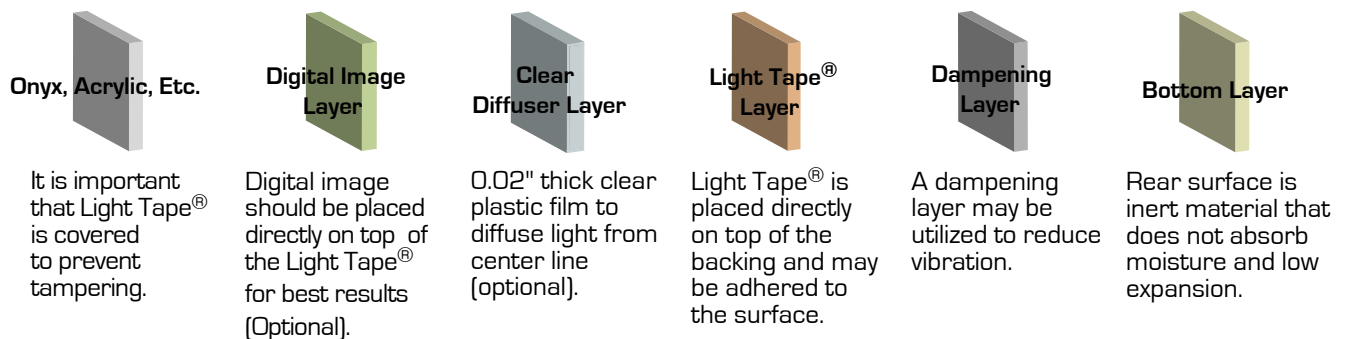

NO MORE BULKY LIGHT BOXES! BACKLIGHT IMAGES EASILY AND LESS THAN 0.25" THICK!

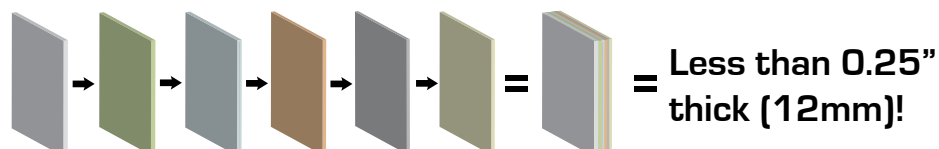

Bring Your Imagination To Light With



Alternative Mounting for Exterior Installations

- **Surface Mount-** Light Tape® is placed on mounting surface and then covered by a plastic lens. Surface mounts are ideal for wood, concrete, brick and other surfaces that DO NOT conduct heat.
- **Flush Mount-** Surface is routed or pre-prepared to accept mounting channel with Light Tape®. Flush mounts are ideal for wood, concrete, brick and other surfaces that DO NOT conduct heat.
- **Suspended Mount-** Light Tape® is placed between two pieces of medium with one being clear. Suspended Mounts are ideal for metallic and other heat conducting surfaces, as it offsets air flow.

Follow the below steps to properly construct your light box to ensure the life of your Light Tape®. Choose an appropriate mount based on the conditions in which the light box will be placed.

Note: For ALL mounts, by sandwiching Light Tape® in a frame, the lamp is able to expand and contract with the weather. The top and sides should be sealed and the bottom is open for drainage.

Front View

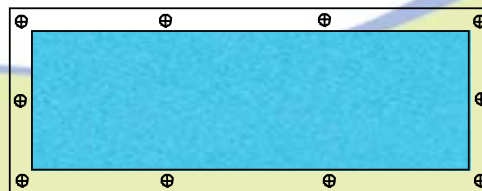

PLACE SPACERS BETWEEN THE FRONT AND REAR LAYER TO ALLOW FOR SLIGHT MOVEMENT!

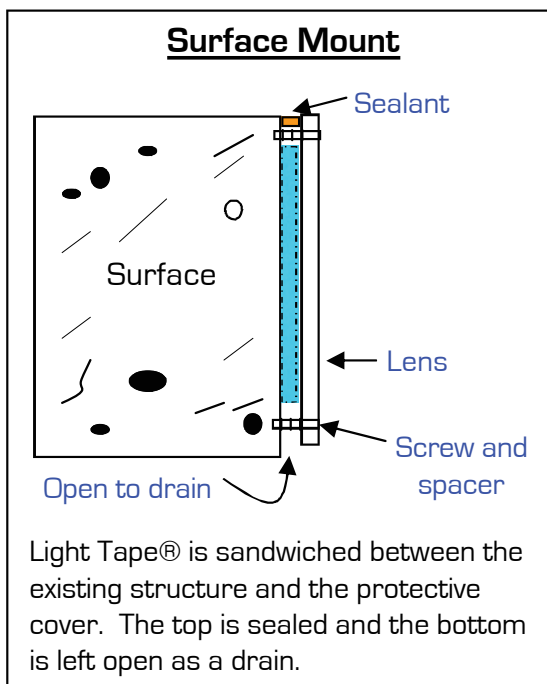

1. Clean surface. It is important that surface is smooth.
2. Sandwich Light Tape® between the surface and the lens, placing a spacer behind the lens. It is recommended that Light Tape® VibraMount™ or other compressible material is placed behind Light Tape®. Note: **Only** adhere foam to surface and not to Light Tape® to allow for expansion and contraction.
3. Screw lens to surface. Apply slight pressure so panel is lightly pressed between the lens and backing on surface.
4. Seal the mount together at the top and sides. Leave a gap or holes at bottom to allow for drainage.

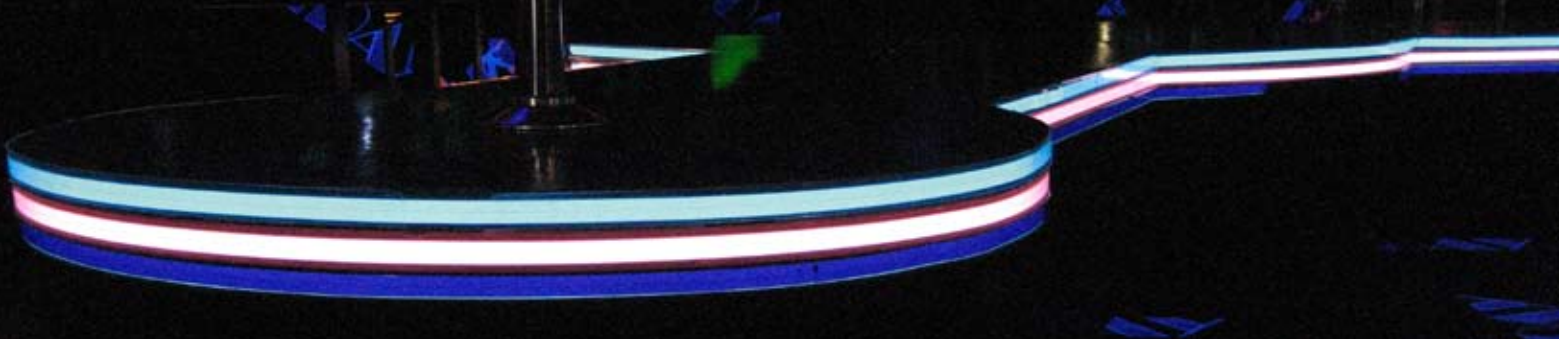

Flush Mount

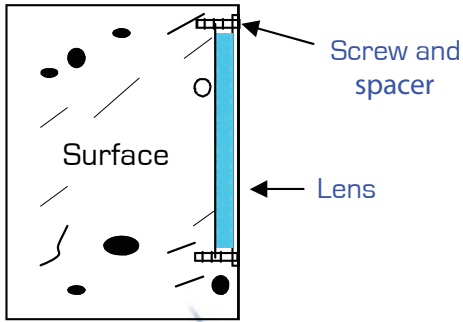

Light Tape® is placed inside a track or channel which has been cut in the existing surface. A lens is then placed to protect from impact and is sealed on the top side.

1. Cut track or channel in existing surface.
2. Clean surface. It is important that surface is smooth.
3. Sandwich Light Tape® between the surface and the lens, placing a spacer behind the lens. It is recommended that Light Tape® VibraMount™ or other compressible material is placed behind Light Tape®. Note: Only adhere foam to surface and not to Light Tape® to allow for expansion and contraction.
4. Screw lens to surface. Apply slight pressure so panel is lightly pressed between the lens and backing on surface.
5. Seal the mount together at the top and sides. Leave a gap or holes at bottom of the sign to allow for drainage.

Suspended Mount

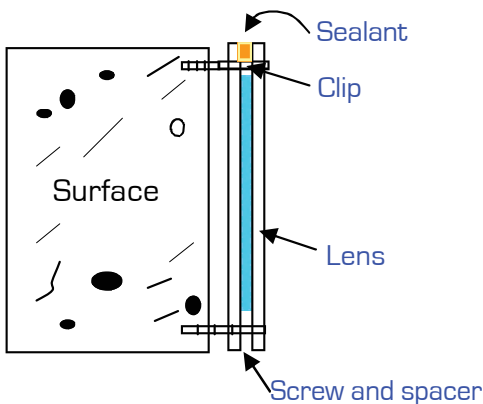

Ideal for suspending Light Tape® away from surface. Recommended if surface is susceptible to extreme heat, such as metals.

1. Utilize smooth materials to construct lenses.
2. Sandwich Light Tape® between two plastic lenses with spacers separating the Light Tape® from the lenses. Apply slight pressure so that panel is lightly pressed between the lenses.
3. Screw mount to surface.
4. Seal the mount together at the top and sides. Leave a gap or holes at bottom of the sign to allow for drainage.