



## Smart Driver™ Lighting Ballasts: DC Input

Smart Driver™ Lighting Ballasts are engineered to illuminate Light Tape®. Whether it is one lamp or ten, it is possible to do it all with one ballast. Compact sizing makes DC power supplies ideal for specific applications. All you need to know is the total surface area of the Light Tape® you wish to illuminate!



Intelligent Electroluminescent Power Source

### Features

- Mountable or Portable
  - Compact in size
- Available with or without mounting platform
  - Temperature range: -30°C to +85°C
    - High Efficiency
- Reverse Polarity Protection
  - No Load Protection
- Short Circuit Protection
  - Self Compensating
  - Quiet Operation
  - Small Form Factor
  - CE compliant

Light Tape® can be operated with standard batteries. With such a low current draw, it is possible to achieve hours, if not days, of illumination with one charge. Our DC inverters are able to accept a variety of input voltages. However, our standard input is 12 volt unless otherwise specified. Alternate input voltages (3 vdc, 6 vdc, 9 vdc, and 24 vdc) are available upon special request for quantities of 250 or more.

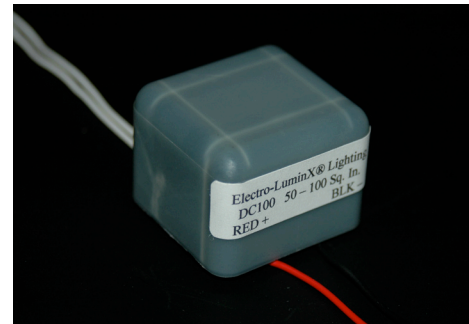

Pictured above and below: DC-100

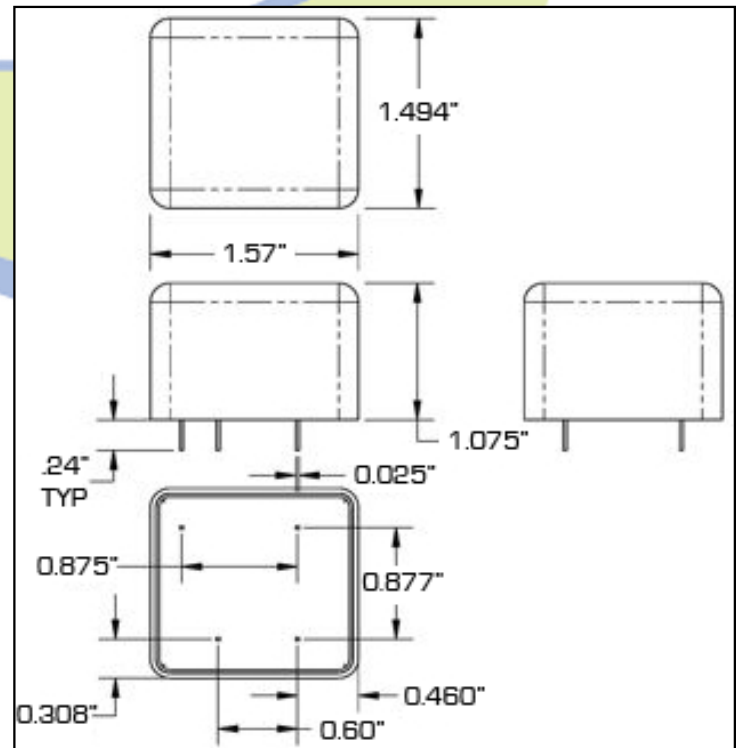

Model	Lamp Area	Output Voltage Range	Frequency Range	Dimensions	Weight
9V	1-33 sq. in.	225-250 VAC	1 khz	2.31" x 2.31" x 0.94"	0.15 lb / 2.4 oz
DC-20	1-20 sq. in.	200-260 VAC	600-700 hz	1.0" x 0.82" x 0.7"	0.1 lb / 1.6 oz
DC-50	20-50 sq. in.	200-260 VAC	600-700 hz	1.2" x 1.1" x 0.82"	0.2 lb / 3.2 oz
DC-100	50-100 sq. in.	200-260 VAC	600-700 hz	1.57" x 1.49" x 1.08"	0.31 lb / 4.96 oz
DC-150	50-150 sq. in.	200-260 VAC	600-700 hz	3.88" x 2.08" x 1.5"	0.6 lb / 9.6 oz
DC-500	100-500 sq. in.	200-260 VAC	600-700 hz	5.14" x 2.33" x 1.74"	1.85 lbs / 29.6 oz
SD-1800	600-1800 sq. in.	250-350 VAC	500-1000 hz	6.19" x 3.94" x 2.07"	2.4 lbs / 38.4 oz