

StepGuard™ 45

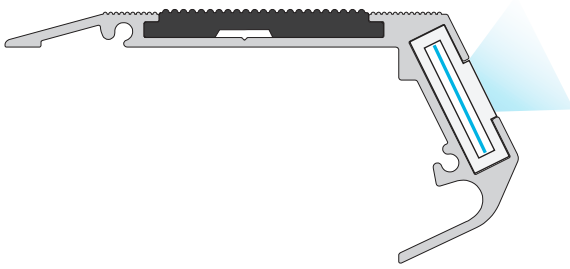

SG-45: Our Most Popular Design

The SG45 design uses one Light Tape® lamp visible at a 45 degree angle when walking up and down the steps. When seated, you cannot see illuminated lights in front of you while watching the film. Only when standing as each step illuminates due to viewing angle as you descend, as if they were being turned on for your every step.

Recommended for flat floors or low pile carpet venues.

System and Parts

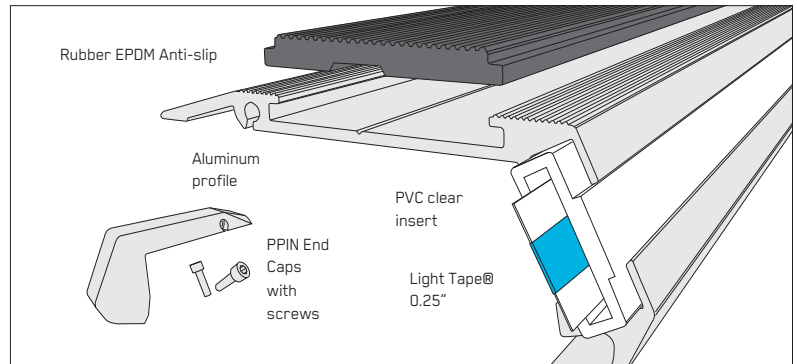

Design Features

- Arrives Plug & Play ready for installation, IP65 rated
- Illuminated by Light Tape® Electroluminescent lamp
- Aluminum profile length tolerance: +/- 3mm
- Extremely energy efficient: 1 / 4 watt per meter
- Fully compliant - TUV IECEE IP65 certified
- Aluminum profile with non-slip insert on top
- Screws into step for quick installation.
- Mechanically fastened end caps, not glued

How to Order:

- Part Number - SG-45
- For a basic quote, we need the number of steps per cinema and average width per step to determine power layout. We also offer a service where we will go through architectural files to determine what is required for the installation.
- For final sign-off we will verify color of Light Tape®, on-site step widths and which side of step for electrical connection based on plan.

Available Colors



- No glare, completely uniform light with no heat .
- 1/4 watt per meter. 10% of LEDs at same brightness.
- Only 3 milli-amps of current per a linear meter step .

Rapid Installation

- Always use Heat Shrink Tubing Thin Wall, 2:1 Shrink Ratio to seal connections between profile lead and your main wiring.
- To fix profile on surface, we recommend using 1/4 x 2 1/4 screw with nylon anchor every 10cms / 3.93 inches.

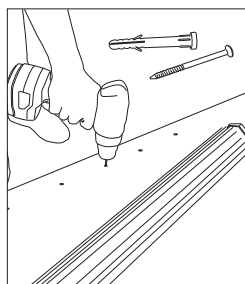
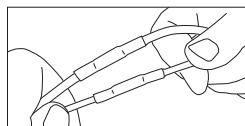

For step by step installation process, please refer to our installation manual guide.

SG-45 Dimensions

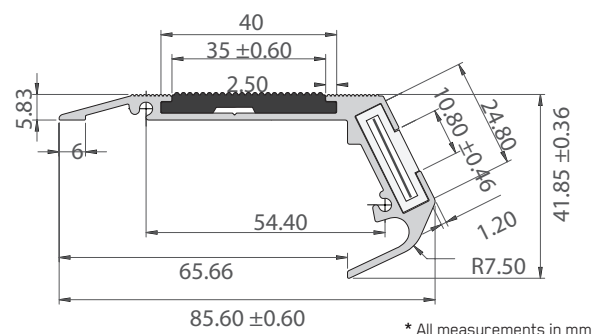

* All measurements in mm

Color Options

Our base colors are Classic Natural Blue and Extreme Blue-Green. These colors appear white when off and colored when illuminated. We then add a filter to produce specific color options. All other colors will remain that color when not illuminated. Please check our website for updated and new colors.

Classic Series

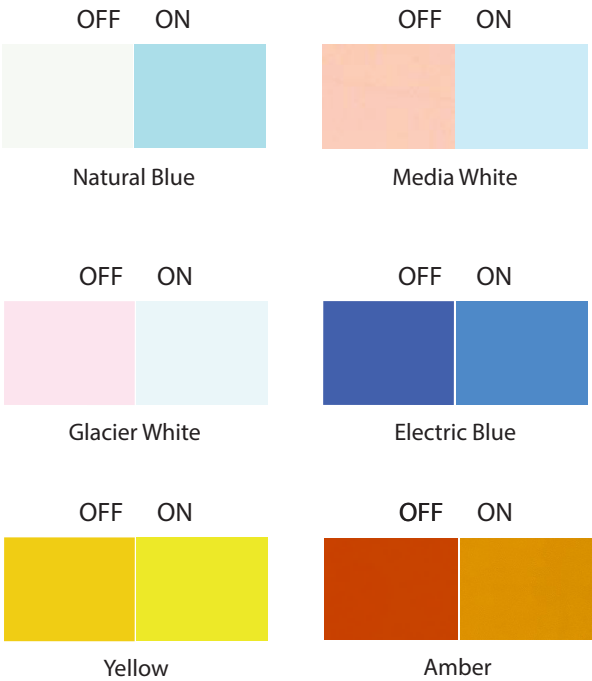

A	B	Inches
6.35mm	19.05mm	0.25

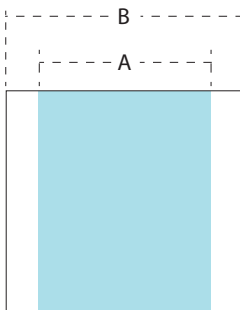

A= Illuminated width
B= Laminated width

Extreme Series

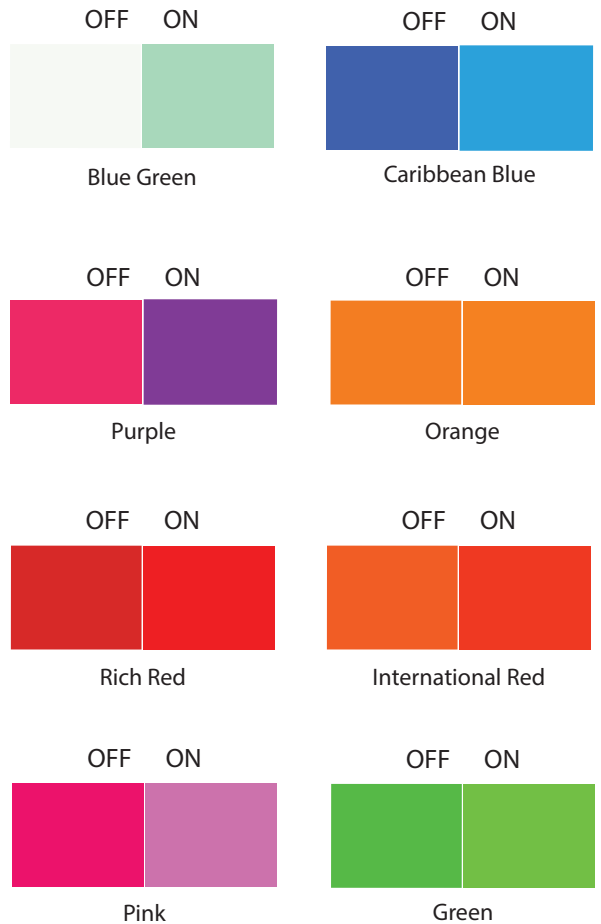

* The colors in this table are simulated and the final product may vary. If an exact color is required, we recommend seeing a physical sample. Custom colors and widths are available, but may be subject to minimum order quantities, set-up fees, and approval testing.

Digital Smart Driver™ Power Supply

Digital Smart Driver™ power supplies are specifically engineered to illuminate Light Tape®. Whether it is one segment or 80, it is possible to do it all with one Smart Driver™. There are a variety of models to choose from offering a variety of useful features. A factory representative will advise which model to use based on the total illuminated area, zones, and location.

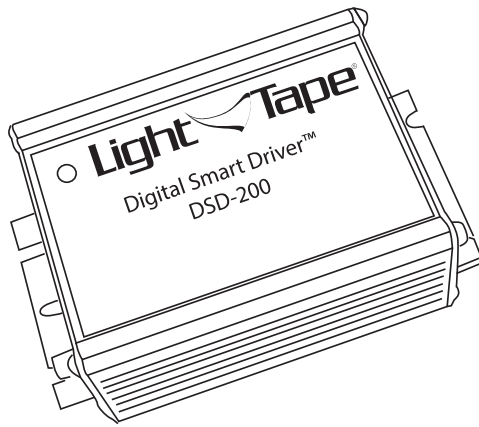

- Quiet
- Stylish compact design
- Rated input voltage 110 / 220 VAC
- Protection Class 1
- IP Degree 2x
- Worldwide voltage capacity
- Blink and Dimmer Switch
- Visual LED system status indicator
- Lightweight
- Short circuit and overload protection
- CE, UL y CSA compliant
- 0-10 dimming

Driver Ranges and Output

Driver Model	Range		Input		Output
	English System	Metric System	Ams	Watts	Max. Current, A
SD-8000	4000 - 8000 in ²	25,806 - 51,612 cm ²	3.50	420	3.8
BUS-DSD-4000	2000 - 4000 in ²	25,806 - 51,612 cm ²	3.50	420	3.8
DMX-DSD-4000	2000 - 4000 in ²	12,903 - 25,806 cm ²	1.5	145	2.1
DMX-DSD-2000	1000 - 2000 in ²	6,451 - 12,903 cm ²	1.0	110	1.2
DMX-DSD-1000	400 - 1000 in ²	2,580 - 6,451 cm ²	0.9	100	1.0
DMX-DSD-200	1 - 200 in ²	6,5 - 1,290 cm ²	0.5	12	0.15
DSD-200 D	1 - 200 in ²	6,5 - 1,290 cm ²	0.5	9	0.15
DSD-2000	1000 - 2000 in ²	6,451 - 12,903 cm ²	2.8	68	0.91
DSD-1000	400 - 1000 in ²	2,580 - 6,451 cm ²	0.9	97	0.32
DSD-400	200 - 400 in ²	1,290 - 2,580 cm ²	0.7	17	0.11
DSD-200	1 - 200 in ²	6,5 - 1,290 cm ²	0.5	9	0.15

*Max Vac is 320v at 750hz

Smart Driver™ Safety & Handling

It is important that you operate Light Tape® and Smart Driver Power Supplies within their parameters. Changes to parameters that result in over current will damage the Light Tape® lamp and power supplies.

- Always attach Light Tape® load before powering .
- 250 volts is mid-range and recommended set point.
- The external dimmer switch on Smart Driver™ controls the output voltage and frequency.
- Use a voltage meter to determine volts /hertz from Smart Driver™ to Light Tape®.
- Always set power supply output voltage per factory recommended setting.
Low: 200 volts | Medium: 250 volts | High: 300 volts
- We DO NOT recommend exceeding 300 volts. Contact us if the Smart Driver™ is operating outside of range .
- Red LED indicates the following :
 - a.Short Circuit Protection : Check wiring if light is on.
 - b.Overload Protection: Verify that lamp area is acceptable, or for possible damage to lamp.
- Always treat Light Tape® and Smart Driver™ with care and respect as one would with any device where electrical current is present
- Please store in appropriate NEMA enclosure for outdoor/ damp location.
- Please follow local electrical codes .

Digital Smart Driver™ Power Supply

Features

- StepGuard® is exclusively made for Light Tape®
- DMX Mode- 512 Supplies are fully DMX controllable, allowing for integration into complicated stage and light show.
- Blink Mode- Allows for on/off pulse control with fine turning knob.
- Brightness Control- luminosity adjustment to appropriately match installation environment.
- 0-10 Dimming- Optional function to remotely control Light Tape® brightness using standard 0-10v dimmers. Compatible with Lutron Dimmers.

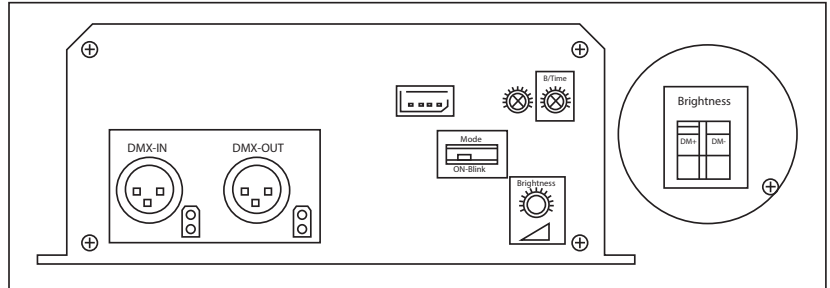

Driver Model	DMX	BLINK	BRIGHTNESS	0-10
SD-8000		X	X	
DSD 200 0-10 DIMMING			X	X
DSD 4000 DMX	X	X	X	X
DSD 1000 DMX	X	X	X	X
DSD 200 DMX	X	X	X	X
DSD 2000			X	X
DSD 1000			X	X
DSD 400			X	X
DSD 200			X	

Power Supply Dimensions

Driver Model	Length		Width		Height		Wheight
SD-8000	9 7/8 in	2.5 cm	4 3/4 in	12 cm	2 1/4 in	5.7 cm	4.15 lb
BUS-DSD 4000	8 3/4 in	22 cm	6 1/4 in	15.8 cm	3 in	7.6 cm	5.15 lb
DMX-DSD 4000	8 6/8 in	22 cm	7 1/4 in	18.5 cm	2 3/4 in	7 cm	4.9 lb
DMX-DSD 2000	8 6/8 in	22 cm	7 1/4 in	18.5 cm	2 3/4 in	7 cm	4.9 lb
DMX-DSD 1000	7 3/4 in	19.5 cm	3 3/8 in	8.5 cm	2 in	5 cm	1.85 lb
DSD 200 DMX	6 in	15.5 cm	2 5/8 in	6.75 cm	1.5 in	4 cm	0.85 lb
DSD 200 D	6 in	15.5 cm	2 5/8 in	6.75 cm	1.5 in	4 cm	0.8 lb
DSD 2000	8 3/8 in	22.5 cm	3 3/8 in	8.5 cm	2 in	5 cm	2.05 lb
DSD 1000	7 3/4 in	19.5 cm	3 3/8 in	8.5 cm	2 in	5 cm	1.85 lb
DSD 400	6 5/8 in	16.5 cm	2 5/8 in	6.75 cm	1.5 in	4 cm	1.05 lb
DSD 200	4 7/16 in	11.3 cm	2 3/4 in	7.0 cm	1 5/8 in	4.1 cm	0.70 lb

Export Packing

Features

- Sturdy Palletized Wooden Crate made of Certified Wood as per International Standard for Phytosanitary Measures (ISPM15 or NIMF15).
- Sealed with screws and secured with plastic bands and two security labels with consecutive numbering or code.
- Every box is stenciled with logos and description of content.
- Interior of crate is protected with kraft paper and bubble wrap for extra protection.
- Every Box is made to size according to customer's order.

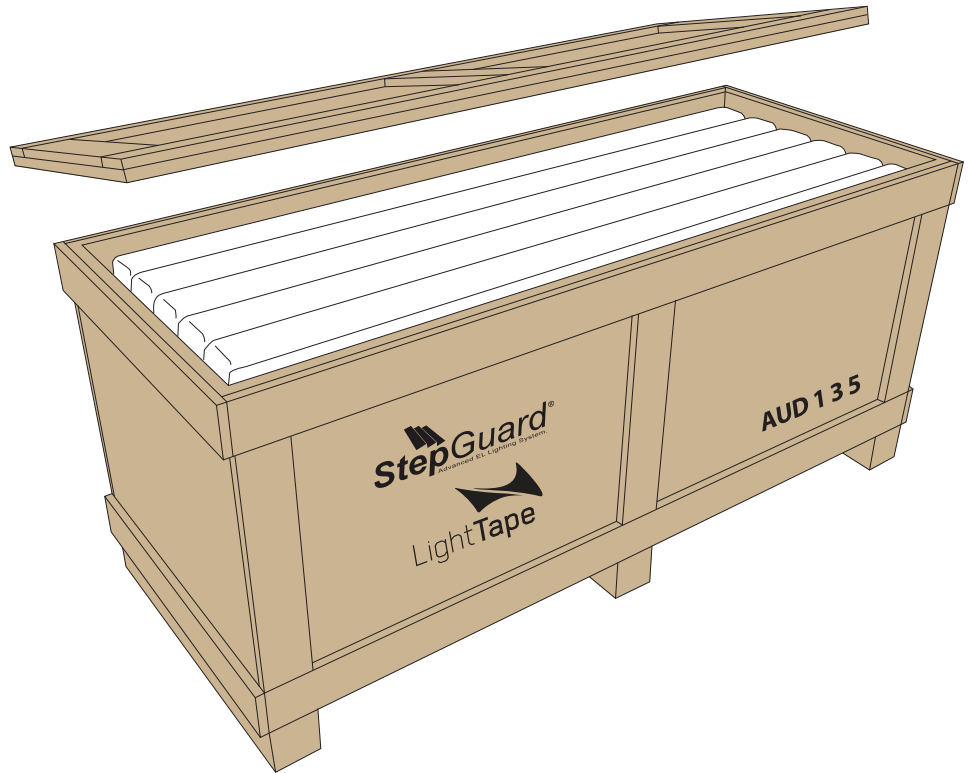

Packing Unit

Units are packed in pairs (as per detail). Box includes also Smart Drivers and spares if requested.

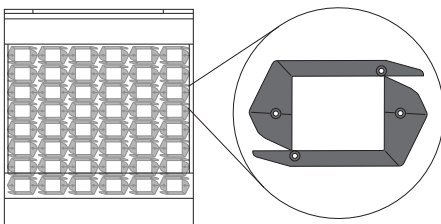

Packing unit
(6 x 10 cms)

Box Dimensions

Height (front view)

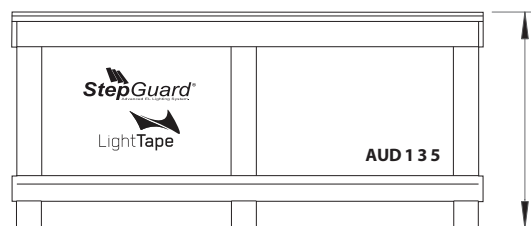

Height of box is calculated by taking the quantity of steps, divided by 12 which is the maximum quantity per row (six pairs). Then adding 6 cms to packing unit and 14cms for the skids and box wall.

Length (top view)

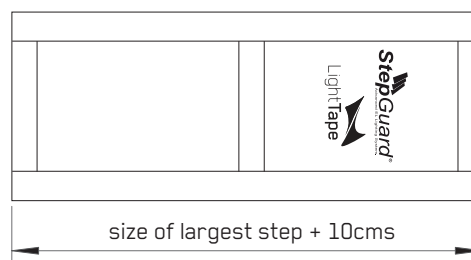

Depth (side view)

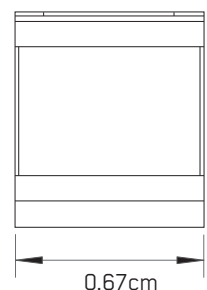

STEPGUARD[®]
INSTALLATION GUIDELINES



Surface and Profile Preparation

1.

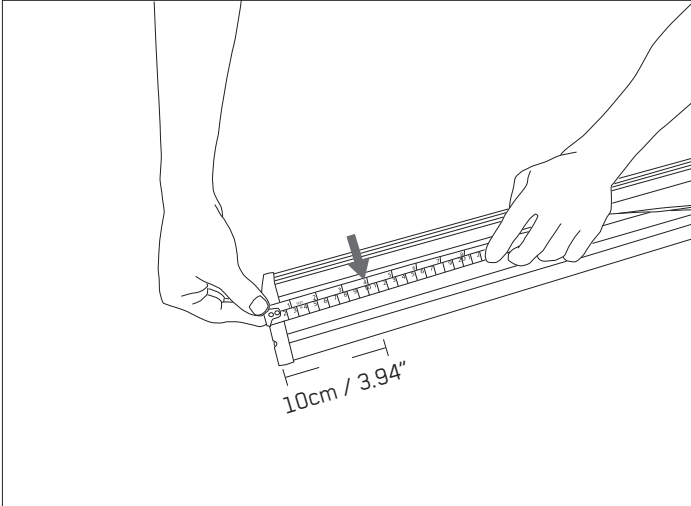

First step is to measure and mark the holes on the profile. We recommend a maximum distance of 10cm on the sides and the other holes should be distributed equally throughout the profile.

IMPORTANT: There should be at least 4 screws per linear meter to ensure a proper fix on surface.

2.

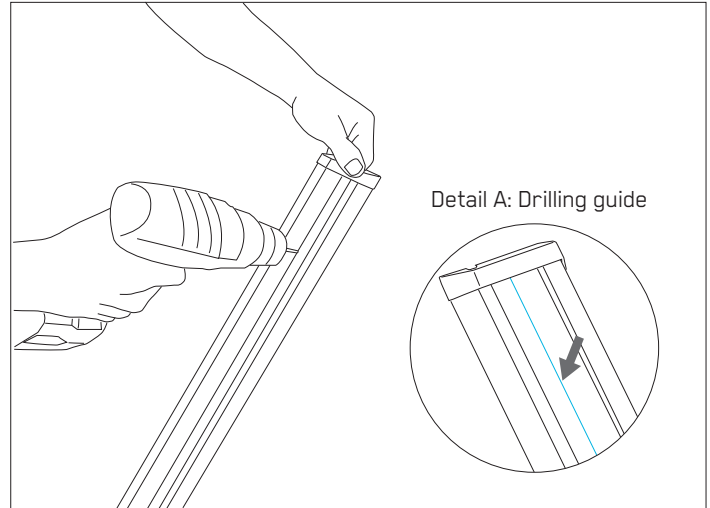

Once you have the marks on the profile, use a metal drill to make the holes. Remember to always use the drilling guide to mark and drill holes as per **Detail A**, because the anti-slip will fit the head of the screws on this area to avoid bumps on it.

3.

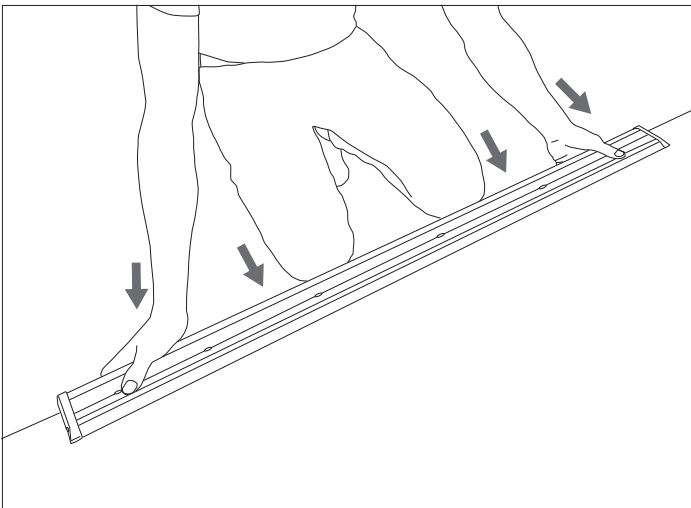

Locate the profile on its position and push it against the stair with both hands and knees to make sure drilling holes are as far possible from corner of step. Make sure profile is secure in its final position.

4.

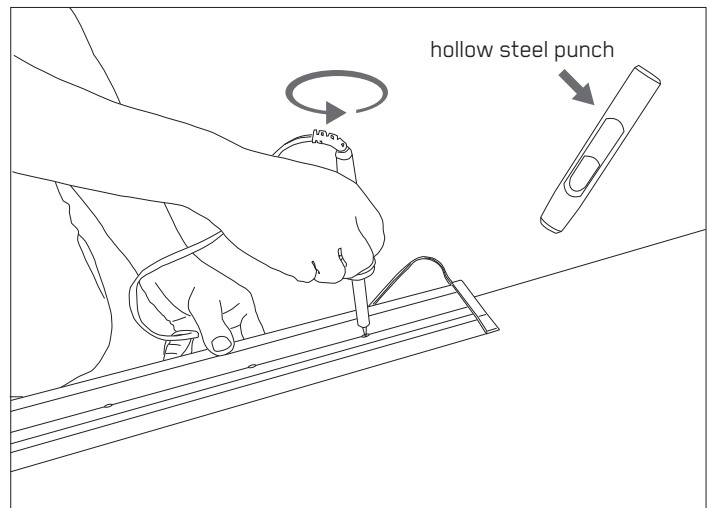

With the help of your knees, keep the profile in its position and burn holes on the carpet with a circular motion on the carpet through the pre-drilled holes of profile. You can also mark the holes on the carpet and use a hollow steel punch or gasket punch (as shown). Now you are ready to drill on concrete without damaging the carpet.

Installing

1.

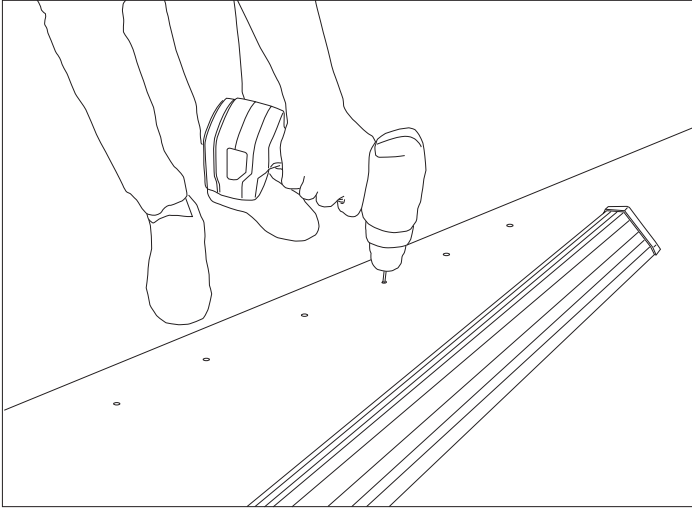

To finalize, drill the holes on concrete or surface and place your screw sledges on place with a hammer. Align profile and screw or hammer on place

2.

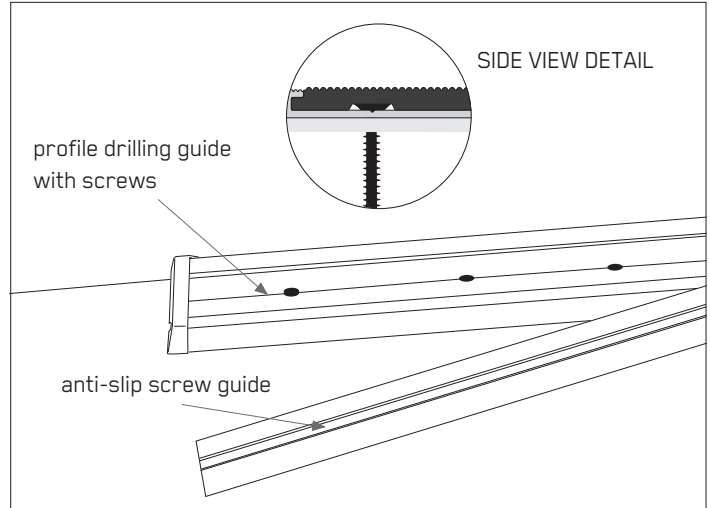

Make sure you place the anti-slip in the correct position matching the screw guide of both parts. No you can begin sliding the anti-slip as explain on next step.

3.

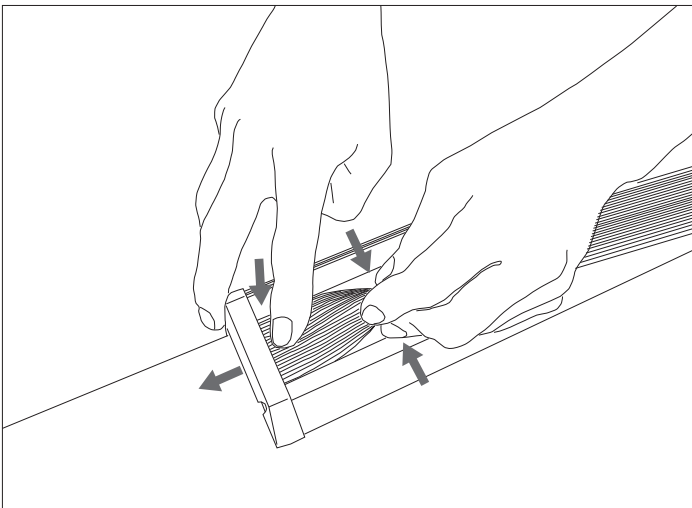

To slide the anti-slip, first push one end underneath the end cap, while pushing the sides. For the rest of the process just push on sides while rubber sits on its position. When finishing on the other side, cut the excess material making sure you leave an extra length (about 1cm-2cm) to fit under the other cap.

4.

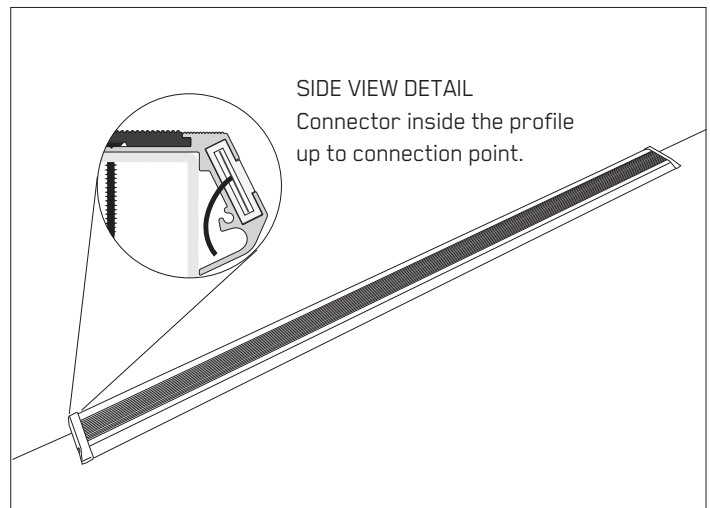

Once unit is installed, do a QC check by stepping on center and sides of the profile, making sure it is fully secured. Also check that connector is hidden inside the profile (see below detail), and there are no loose parts.

Connecting and Wiring

1.

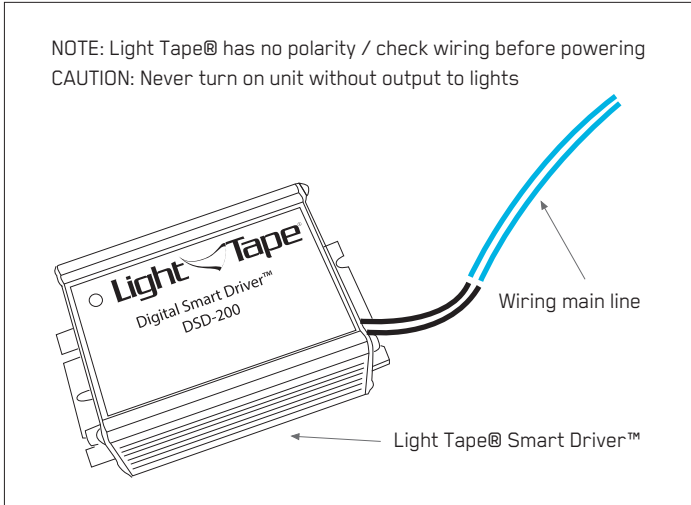

The Digital Smart Driver™ is required to power the Light Tape®. Please make sure you are using the right type of Driver and that is on its illumination range. The driver comes with a dimming button and it should be turned to minimum before powering (if dimming button is included on unit). Once turned on, you can adjust dimmer slowly to desire brightness.

2.

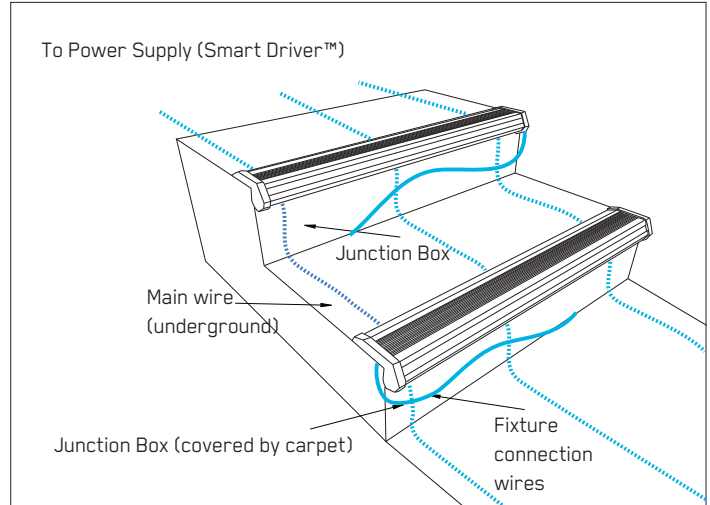

The StepGuard™ step system has been pre-wired to the requested exit side (right or left) when assembling the units at the factory. The main wire, however, can be located through either side or center of the step rows.

3.

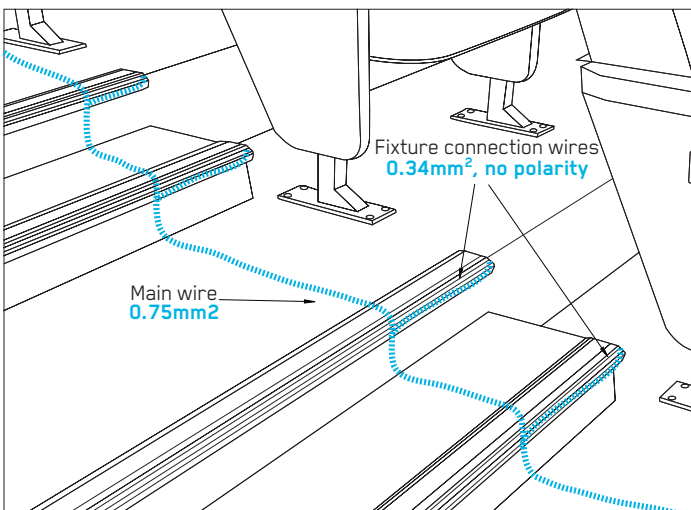

The StepGuard® exit connection wires are supplied with 2x0.34mm² cables. For the main wiring, we recommend using an 0.75mm² cable. Follow all electrical codes when wiring and connecting the system.

4.

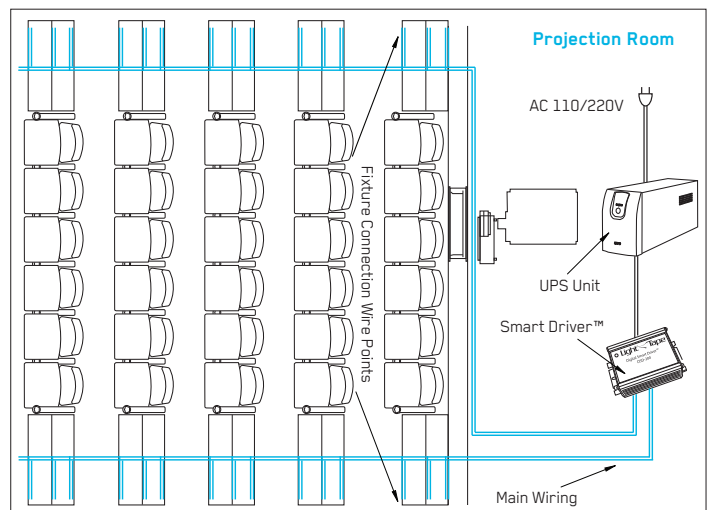

Every step must be properly connected to the main wire following local electrical codes. Please make sure all wire connections are sealed, and there are no loose or pinched wires. For IP65: Dryconn medium waterproof wirenut (#62225) rated for 600V/5A; For standard installation: Ideal 73B orange wire nut rated for 600V/5A; or local equivalent. There is no polarity on Light Tape®.

Type X Connection

The Smart Driver™ Power Supplies, depending on reference, may come with two types of adapters and/or cables to connect to power outlet. In case of damage of cable, this can be easily replaced by user, however the connector or adapter can only be supplied by manufacturer. **To request spares or technical service, please contact: thelighttapeteam@lighttape.com in U.S.A. and rest of the world or : ventas@lighttape.com.co for Colombia and South America.** Please make sure to always include on your request the reference of the Smart Driver™ and/or adapter cable.

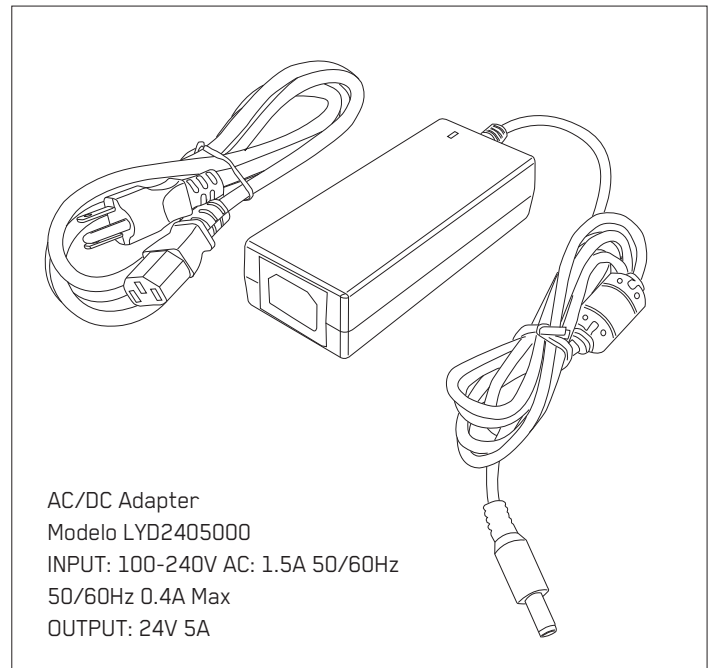
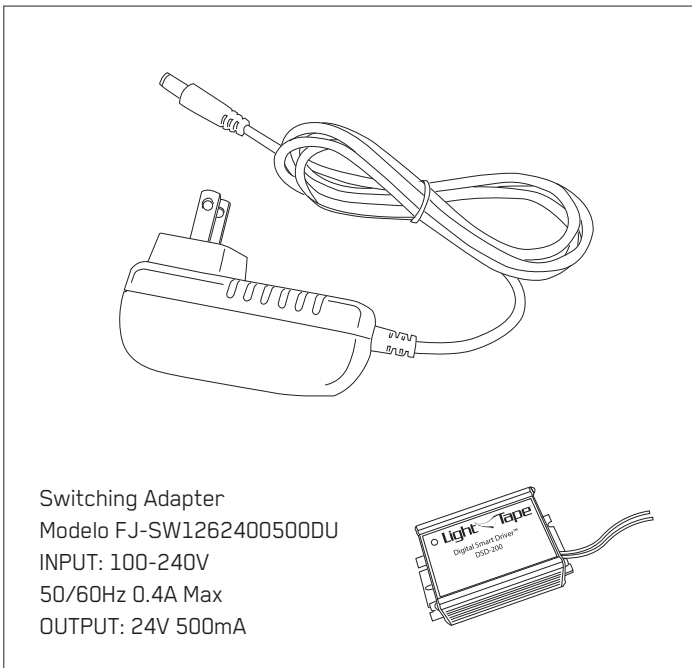

For Type Y Attachments:

If the external flexible cable or cord of this luminaire is damaged, it shall be exclusively replaced by the manufacturer or their service agent or similar qualified person in order to avoid a hazard.

For Non-Replaceable Light Source (Light Tape[®])

The light source of this luminaire is not replaceable. When the light source reaches its end of life, the whole luminaire shall be replaced.

We have a team ready to assist at thelighttapeteam@lighttape.com or +1.804.355.1692



**THIS PRODUCT
CANNOT BE USED ON
INSTALLATIONS OR
FLAMMABLE
SURFACES**



**RISK OF
ELECTRIC SHOCK**

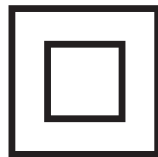

CLASS II



AC CURRENT



INDOOR USE ONLY

**Follow all Electrical Codes
when installing and wiring**

StepGuard Cleaning & Maintenance Information

For external parts of StepGuard™ fixtures

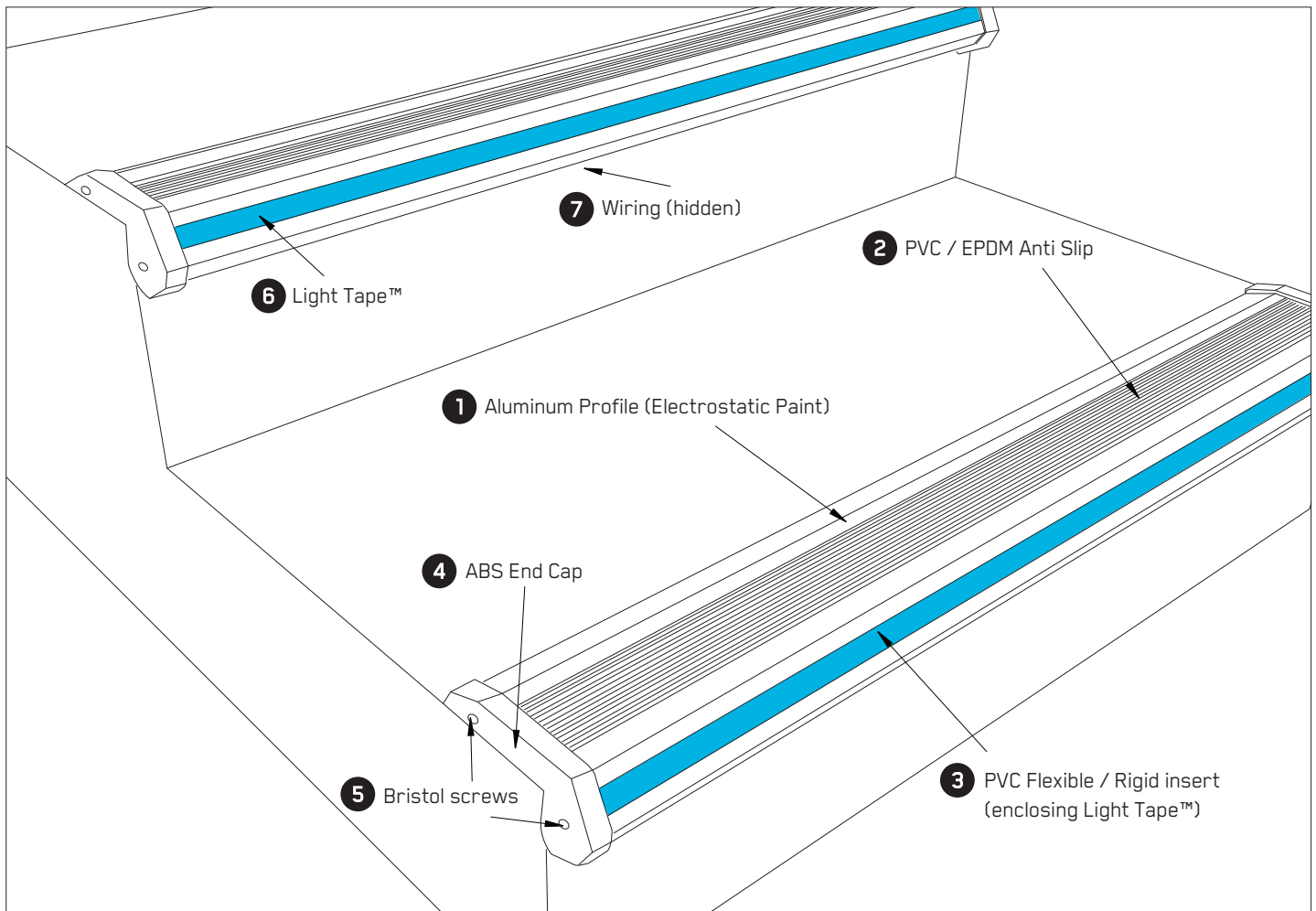

Preventive Maintenance

A visual inspection of the system should be performed regularly. Depending on use but at least once a week the maintenance and/or cleaning personnel should be able to identify that all parts are in place and working properly to run a safe system.

- 1 Aluminum Profiles**
Going down or upstairs will help to make sure all profiles are securely fixed on place. They should not move when stepping on them.
- 2 PVC / EPDM Anti-slip**
Anti-slip should be free of grease and fitted flat on its cavity from end to end.
- 3 PVC Flexible / Rigid insert**
The insert encapsulates the Light Tape™, therefore should be free of cuts or abrasions. No elements should obscure light.

StepGuard Cleaning & Maintenance Information

For external parts of StepGuard™ fixtures

4 ABS End Caps

All end caps must be properly secured to profiles with the screws. Missing, loose or broken end caps should be replaced immediately.

5 Bristol Screws (on end caps)

Both screws should be secured on each end cap. Missing screws or with signs of rust should be replaced immediately

6 Light Tape™

Make sure Light Tape™ lights evenly on its entire length. Lights should not twinkle or blink while on. Light Tape™ should be replaced if signs of humidity, or stains are shown. Please contact Technical Department for more information.

7 Wiring

Inspect that no wires are hanging below fixture. All wiring should be hidden and secure underneath the extrusion.

General Cleaning

A regular cleaning should be performed to prevent the build up of dirt and grease, which could compromise the anti-slip properties and the general appearance of the fixture.

Avoid the use of cleaners containing hydrocarbons, bleach or citrus based agents to clean the StepGuard™ fixtures. You should also avoid the use of steam cleaners, power washers or floor sealants to clean the inserts or end caps.

FOR DAILY CLEANING

Brush down the entire fixture using a soft bristled brush and clean the insert and anti-slip using a damp cloth. Do not soak around the caps or connection or wiring areas.

Aluminum profiles

If heavier marks or sticky stains are seen, clean them using a damp cloth with aluminium safe detergent. Light surface scratches on paint can be removed using a fine wire wool and buffed with a soft cloth. Make sure as much water or cleaning solution is removed as possible.

ABS End Caps / PVC Clear inserts

Only soap and water should be used during ABS cleaning as the use of other chemicals such as chlorides, ketones and degreasers accelerates aging and give them a yellowish color. The cleaning should be done with with a soft cloth or paper. Allow the system to be completely dry.

If you have any doubts or questions regarding product maintenance, please contact our Technical Department at:

Electro-LuminX Lighting Corporation

1320 North Arthur Ashe Boulevard	1.804.355.1692
Richmond, Virginia 23230	+44.7860.967410 GMT
	thelighttapeteam@lighttape.com



StepGuard[®]
Advanced EL Lighting System.



designed for
LightTape[®]

Electro-Luminix Lighting Corporation

1320 North Arthur Ashe Boulevard
Richmond, Virginia 23230

1.804.355.1692
thelighttapeteam@lighttape.com