

AC1 Aisle / Seat Numbering

Design Features

- StepGuard[®] is exclusively made for Light Tape[®]
- Light Tape[®] Electroluminescent lamp
- Smart Driver[™] Light Dimmable & DMX power source
- High Resistance injected PVC case, for heavy duty use.
- OSRAM LED Module for tread illumination.
- Separated wiring: black for Light Tape[®] and polarized for LED Module for easy configuration and setup.
- Units are delivered pre-assembled for easy installation.

Warranty

- 3 Year Limited Warranty on case and accessories for indoor use.

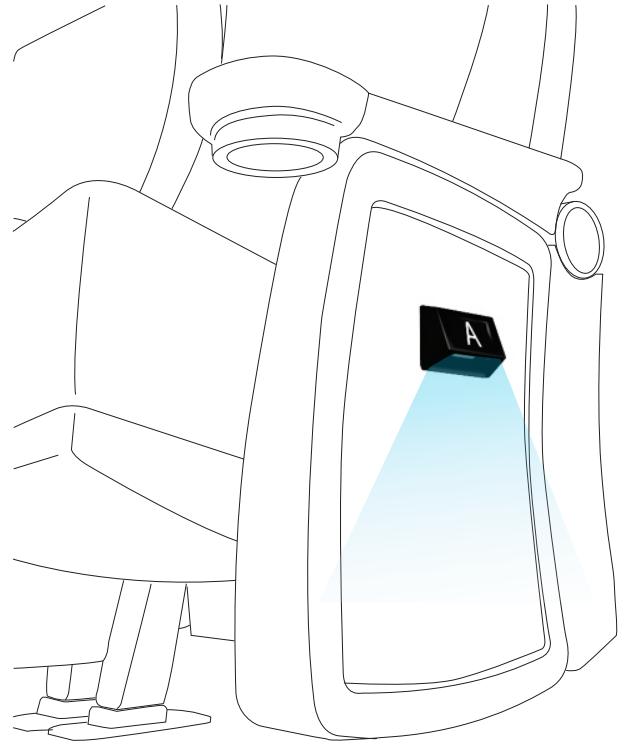

Technical Information

PVC Case

- PVC base and cover case.
- Assembled and customized with sign or letter according to specification.

Light Source

- Light Tape[®] EL tapes. Over 12 colors to choose from. OSRAM LED Module.
- Illuminated width 1.00" (25.4mm)
- Area/Length reference: 7cms
- Illumination source: 100% Phosphors
- Current / amps: 0.01 (meter)
- Total Watts: 1.00 (meter)
- Illumination coverage: 100% even

Design Options

- StepGuard[™] AC1
- StepGuard[™] AC2



StepGuard[™] is exclusively made for Light Tape[®]

StepGuard™ AC1 - General dimensions and configuration

* All measurements in mm

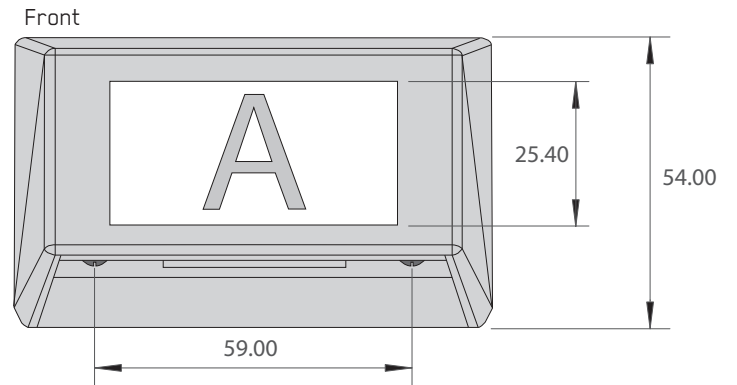
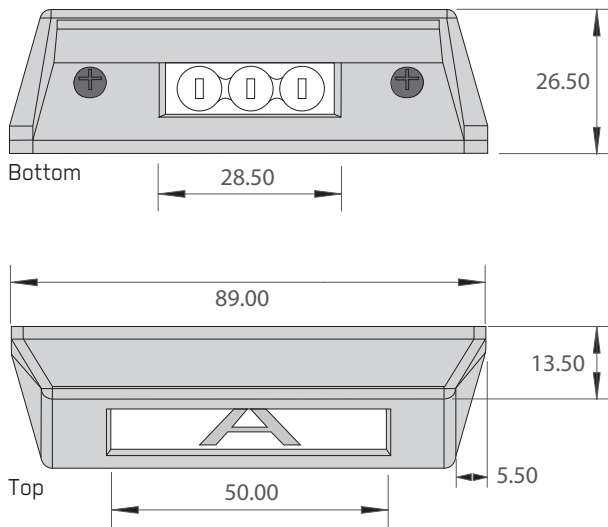

Available Colors

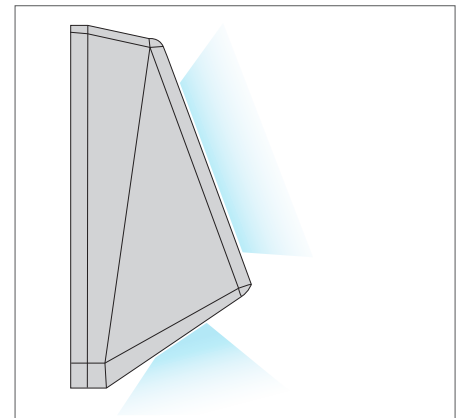

Black PVC unit for aisle chair numbering or signage system. For use with 1" Light Tape® on sign combined with OSRAM LED module on bottom for aisle and tread illumination. Customized with any sign or number in black adhesive vinyl.

