

## StepGuard™ SN / Step Row Number

### Design Features

- StepGuard® is exclusively made for Light Tape® electroluminescent lamps.
- Smart Driver™ Dimmable & DMX power source  
High Resistance ABS case for heavy duty use.
- Polycarbonate enclosure for total protection of light.
- Separated wiring: Unit can be connected to stair Light directly or on a single wiring setup.
- Units are delivered pre-assembled for easy installation.

### Warranty

- 3 Year Limited Warranty on case and accessories for indoor use.



## Technical Information

### ABS Case / Polycarbonate Cover

- PVC base and cover case.
- Assembled and customized with sign or letter according to specification.

### Light Source

- Light Tape® EL tapes with over 12 colors to choose from
- Illuminated width 3/4" (19.63mm) Area/Length reference: 9cms  
Illumination source
- 100% Phosphors
- Current / amps: 0.01 (meter)
- Total Watts: 1.00 (meter)
- Illumination coverage: 100% even

### Design Options

- StepGuard™ SN

### Available for:

- StepGuard™ 45
- StepGuard™ 30
- StepGuard™ Classic
- StepGuard™ Immersion



StepGuard™ is exclusively made for Light Tape®

**StepGuard™ SN - General dimensions and configuration**

\* All measurements in mm

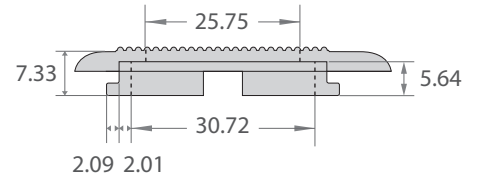
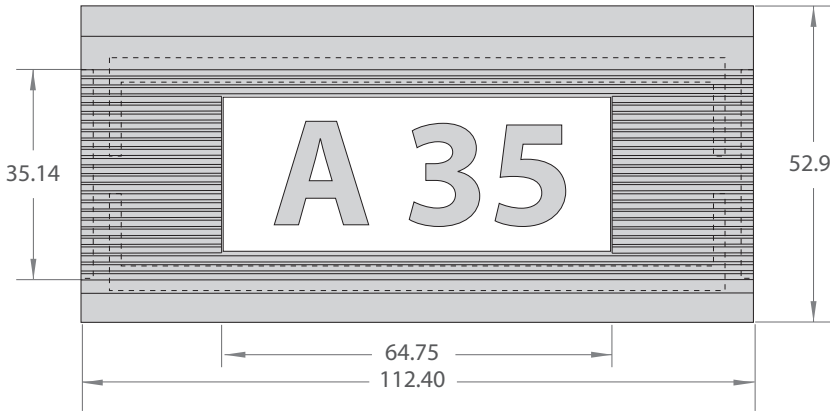

**StepGuard™ SN**

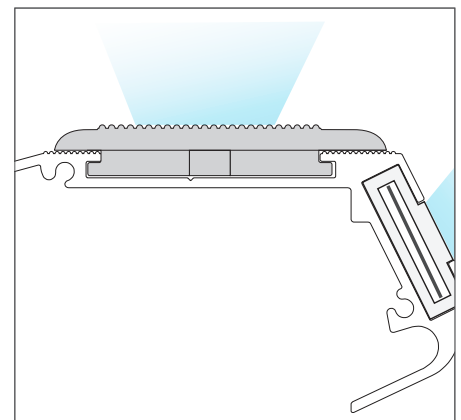

ABS cover / Polycarbonate enclosure unit for row step numbering or signage system. For use with 3/4" Light Tape®.

Customized with any sign or number in black adhesive vinyl.

\*Assembled unit

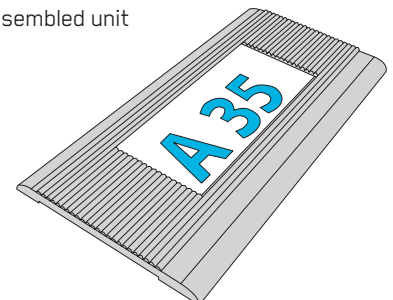

Available Colors

