

WallGuide™ Life Safety

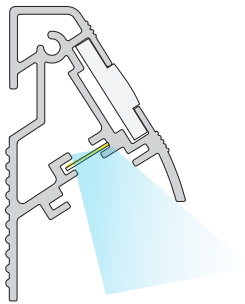

SG-WG-DL-HB: High Bright LED shining down

Our WallGuide™ system is designed to be mounted on the wall to provide navigation illumination for entrance ways and stairs. The system has the ability for direct view and immersive illumination.

The SG-WG-DL-HB has one row of high bright LEDs in the bottom slot to illuminate entrance way to meet local safety codes. Ideal for public or government facilities that require high brightness in entrance and hallways as for Life Safety compliance.

The SG-WG-DL-HB design is recommended for mounting on walls in sections and then feeding LED lamps in a channel specifically designed to house continuous LED strips for navigation.

Design Features

- Profile arrives in sections up to 3 meters in length.
- Illuminated by one Light Tape® Electroluminescent lamp.
- Only one electrical connection required at beginning of profile with no termination connection at other end.
- Aluminum profile length +/-3mm.
- Extremely energy efficient: 1/2 a watt per meter
- Screwed into wall and then hung using rear mount channel.
- End caps as well as corner caps provided for transitions.

System and Parts

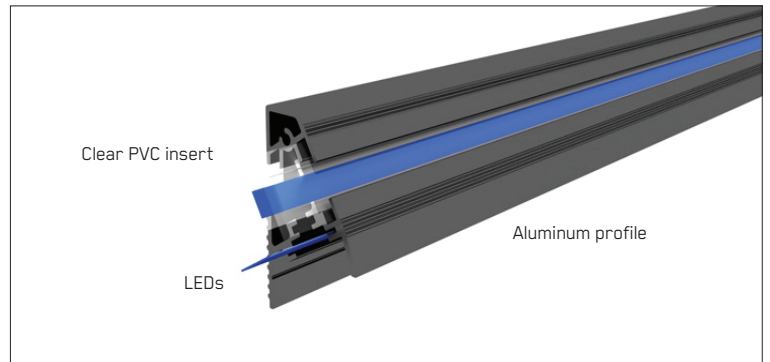

How to Order

- Part Number: SG-WG-DL-HB
- For a basic quote, we need the total length of profile needed per entrance or stairway for us to estimate materials and power.
- We also offer a service where we will go through architectural files to determine layout and what is required for the installation.

Available Colors



- Designed to illuminate walkways and minimize glare
- 5 to 10 watts per meter depending on LED choice
- Insert in top location provides additional navigation guidance

Rapid Installation

- Always use Heat Shrink Tubing Thin Wall, 2:1 Shrink Ratio to seal connections between profile lead and your main wiring.
- To fix profile on surface, we recommend using 1/4 x 2 1/4 screw with nylon anchor every 10cms / 3.93 inches.

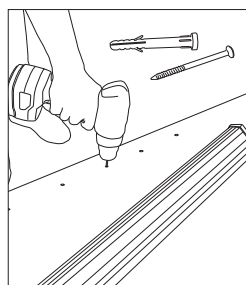
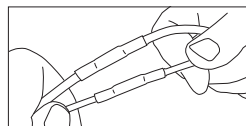

For step by step installation process, please refer to our installation manual guide.

SG-WG-HB Dimensions

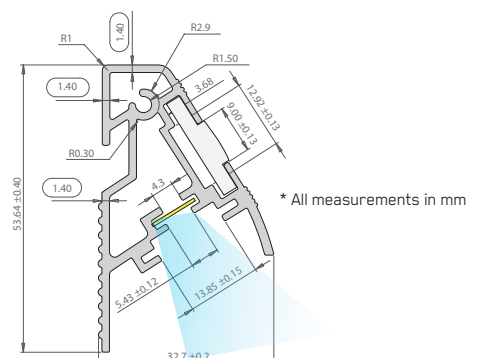

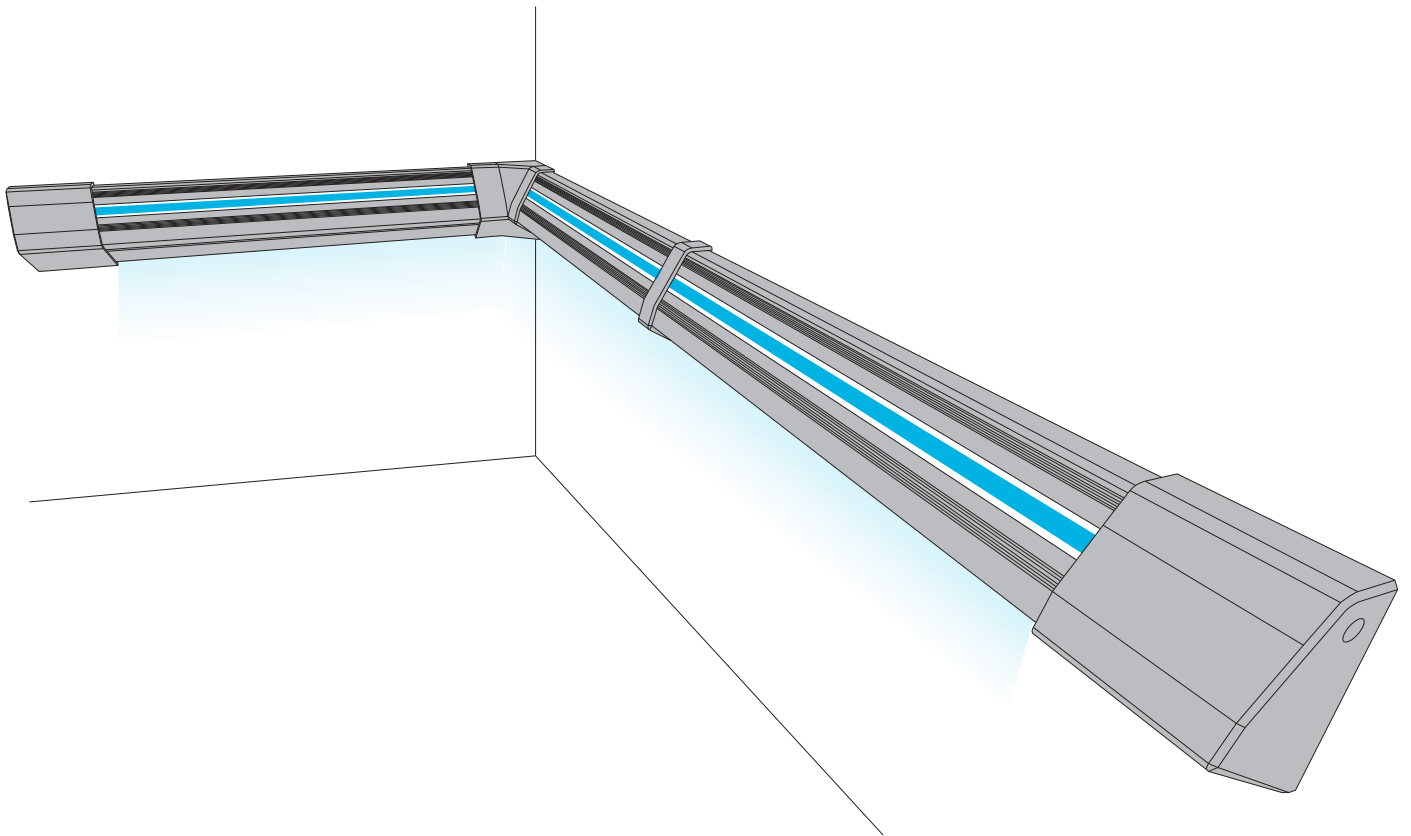

**WALL GUIDE
INSTALLATION INFO**



The WallGuide(tm) Part description

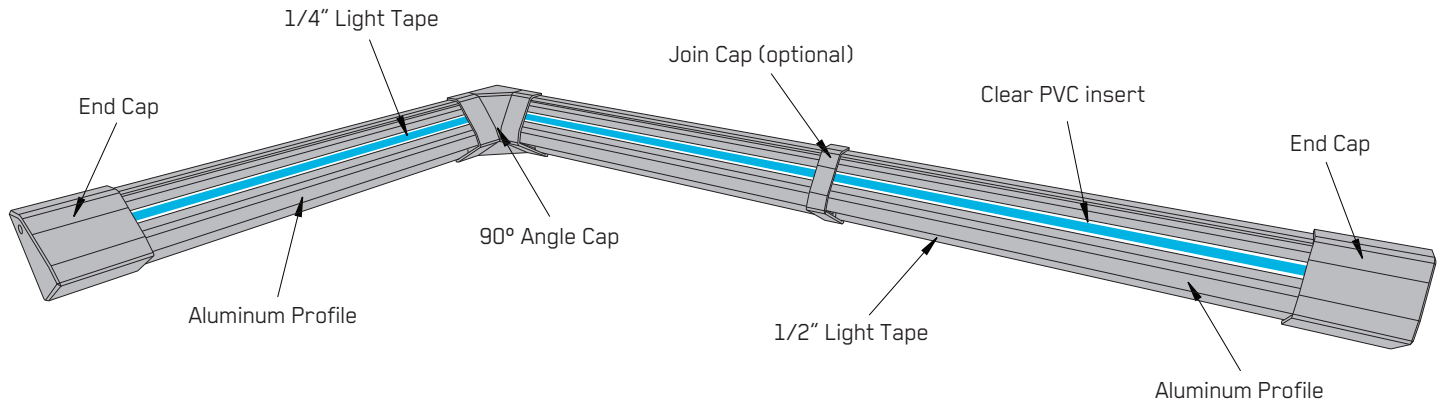

Mounting & Wiring Accesories

End caps

The end caps made of PLA plastic are use to finish the end of a segment. The end caps also hold the connection point on either side. Caps are open on the back, making wiring and connection very easy

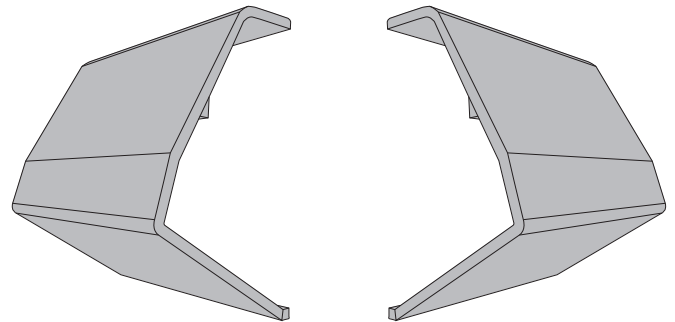

90° angle cap

90 degree angle caps are used as a connection point and to join two segments in a 90 degree inner angle.

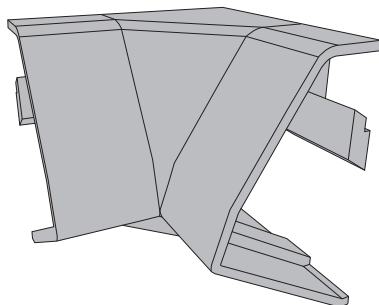

Join cap

Join caps are used to join two segments of the aluminum profiles to hide the edge cuts. Join caps allow light and insert to pass through both segments.

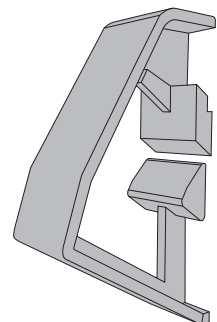

Quick Start Guide

1.

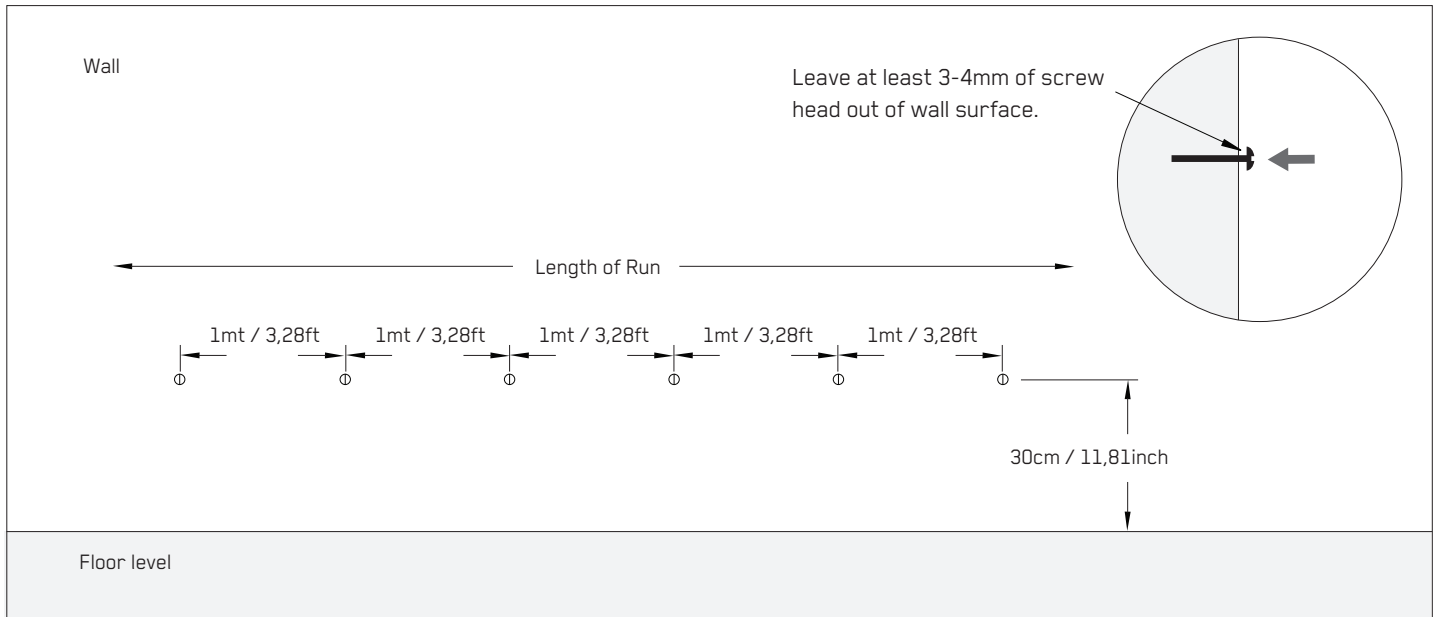

Once length of run is set, mark and drill holes at 30cm/11,81 inch above floor level with a minimum distance of 1 mt / 3,28ft between them, covering the entire length of the run.

2.



Take the aluminum profile and push it against the wall aligning the screws with the mounting cavity as shown.

Quick Start Guide

3.

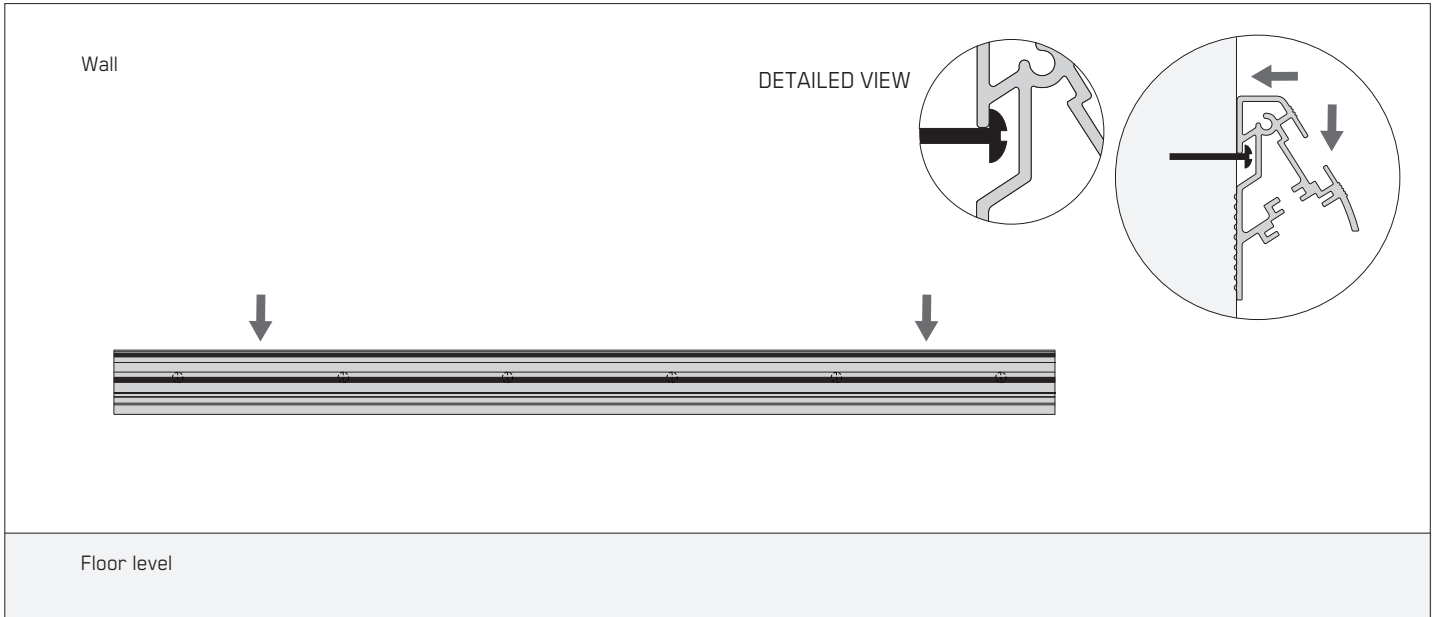

While pushing the profile, pull it down so it will rest on mounting cavity as shown. Push it against you to make sure it is properly resting on screws.

4.

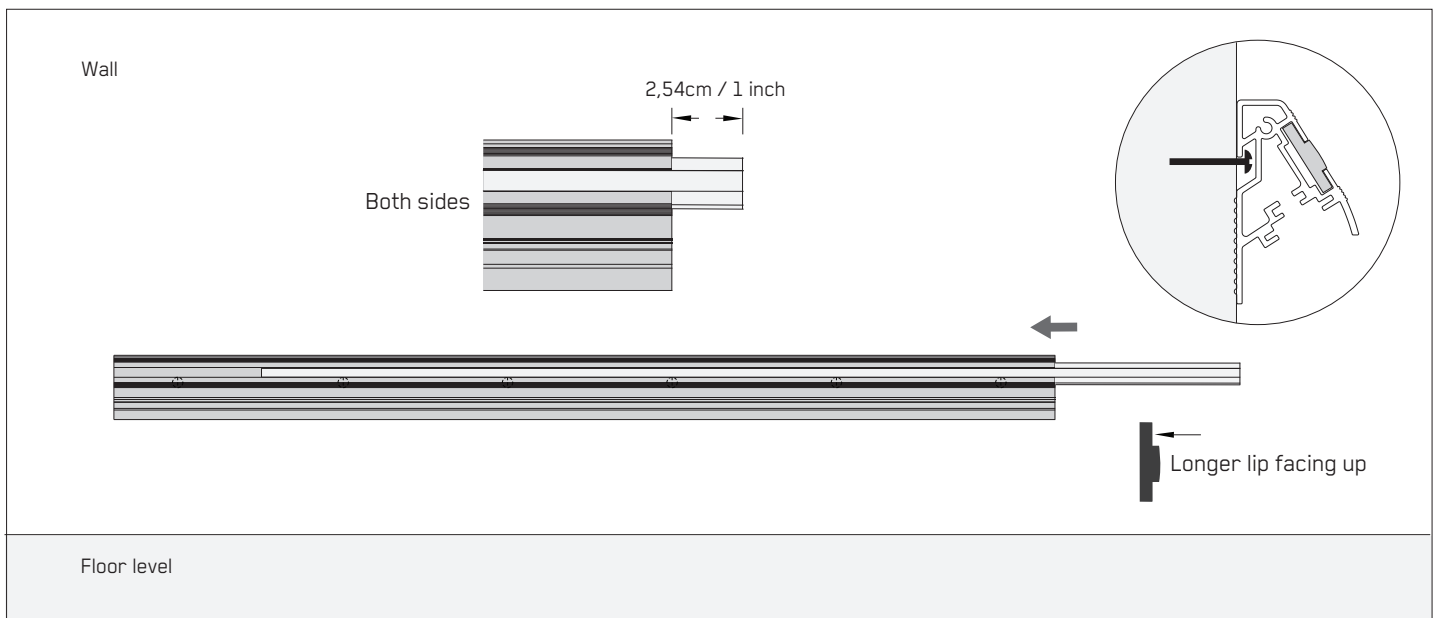

Slide the clear insert on its cavity making sure the longer lip is facing upwards as shown. Cover the entire length of run leaving an additional extra inch out on both sides.

Quick Start Guide

5.

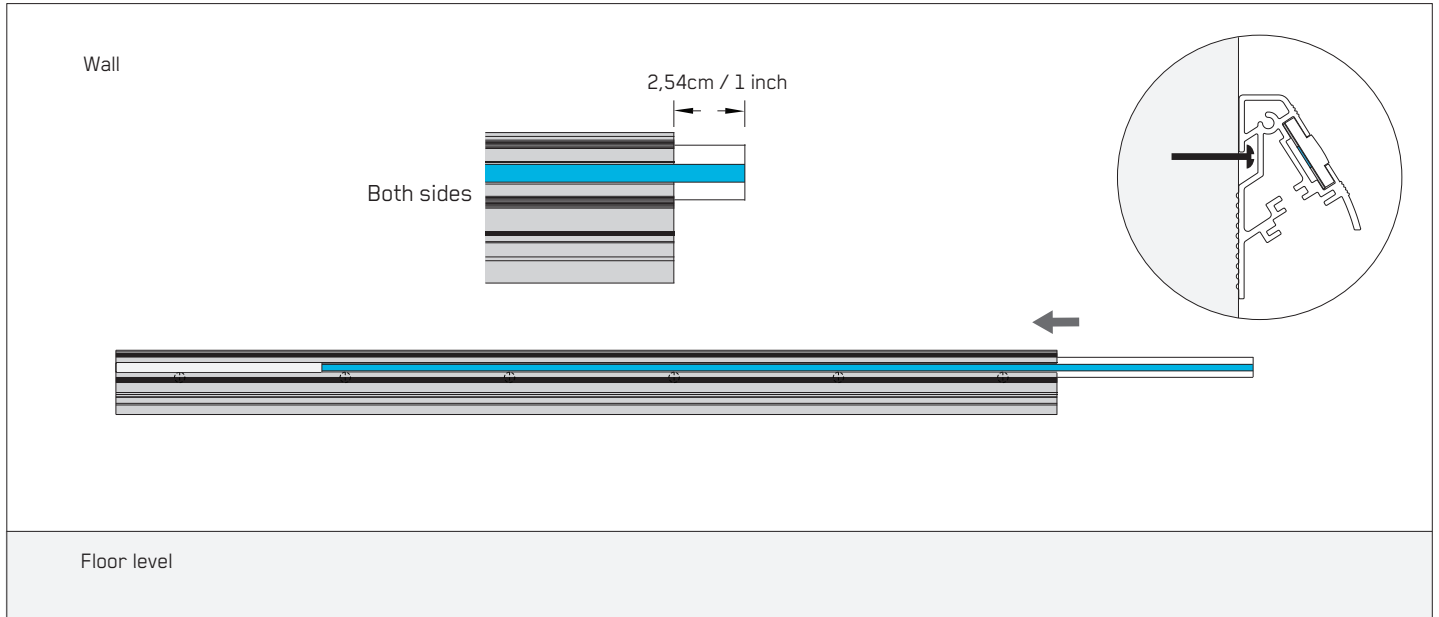

Slide the Light Tape® on its cavity. Cover the entire length of run leaving an additional extra inch out on both sides.

6.

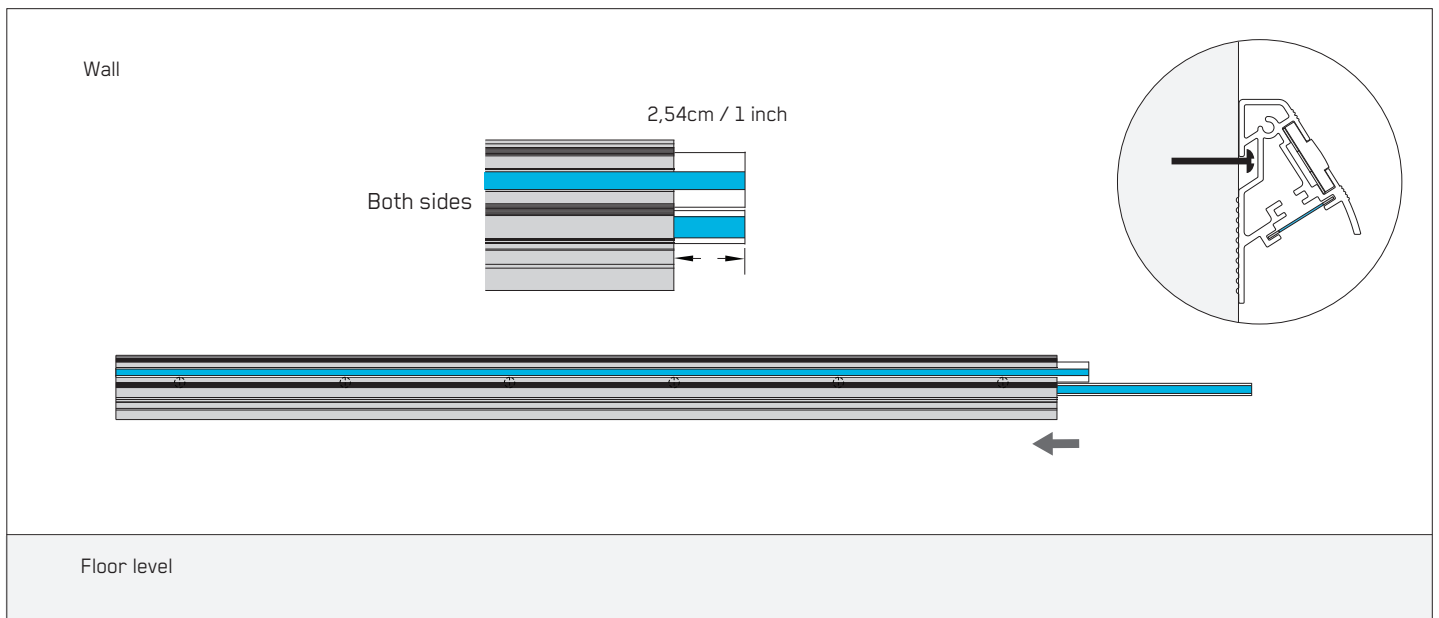

Repeat process for downlight. Cover the entire length of run leaving an additional extra inch out on both sides. Downlight does not use clear protection insert

Quick Start Guide

7.

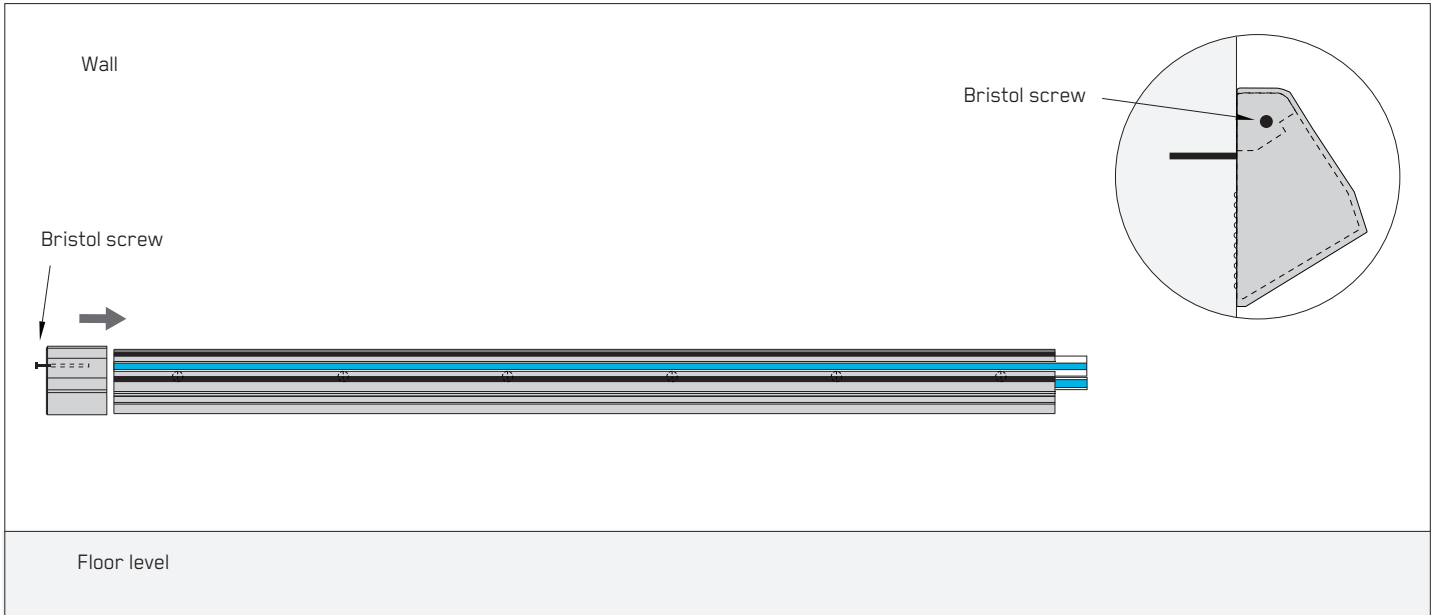

Place the end cap opposite to connection point by sliding it against the profile. Secure with provided bristol screw.

8.

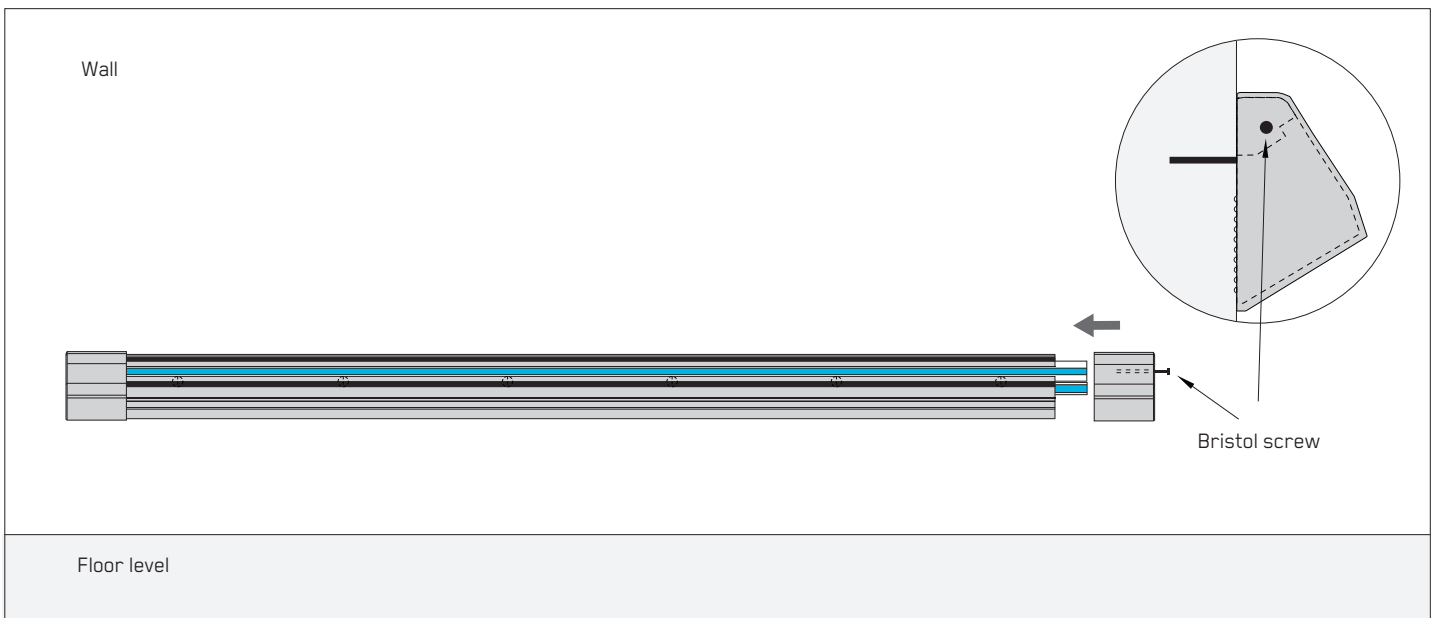

Repeat process on connection point by sliding it end cap against the profile. Be careful with the wires and connector before securing it with provided bristol screw.

Quick Start Guide

9.

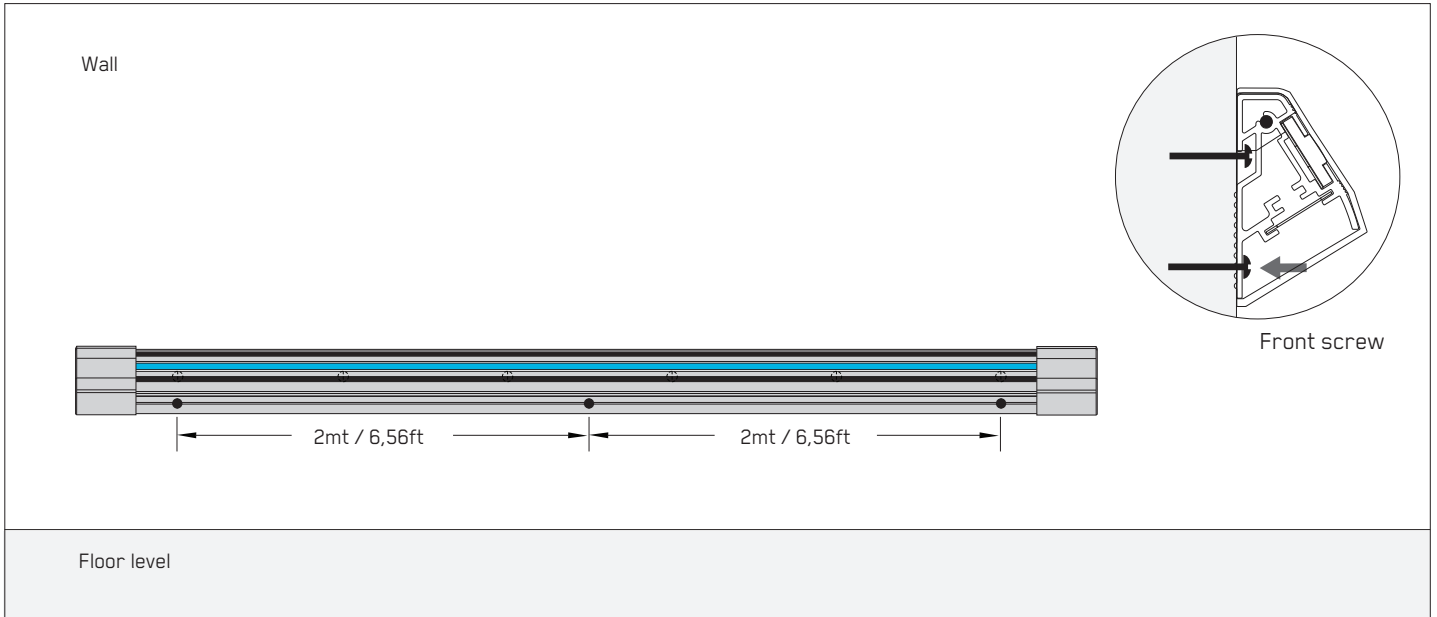

Once system is checked and working, finish the mounting drilling the front screws at least every 2m / 6,56ft from each other.

10.

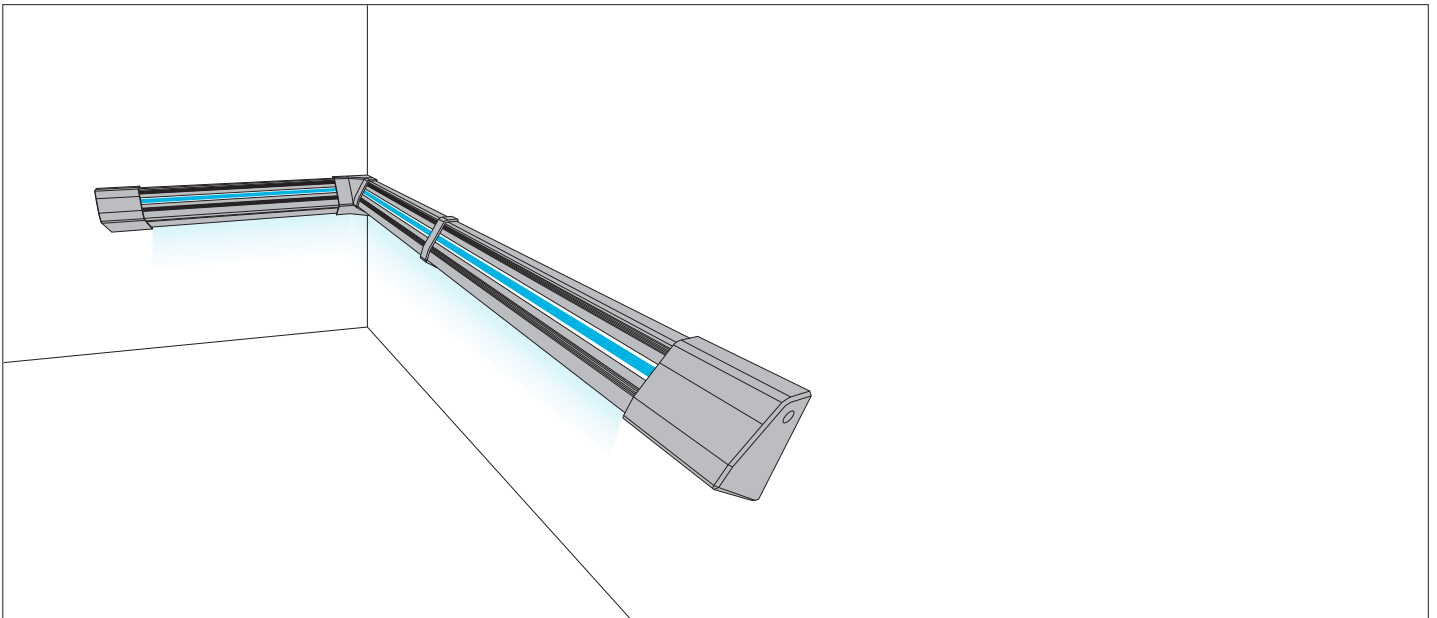

If using angles, repeat process from steps 1 - 9. Placing join caps and angle caps is further explained on this guide.

Wiring options for two segments with 90° angle

Light Tape® Top Connector ———
Light Tape® Bottom Connector ······

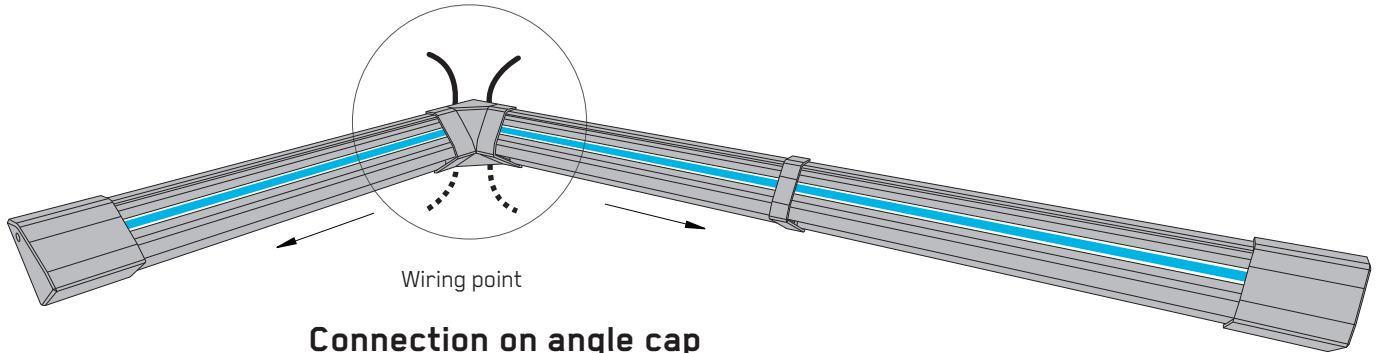

Connection on angle cap

All connections can be located at the angle cap

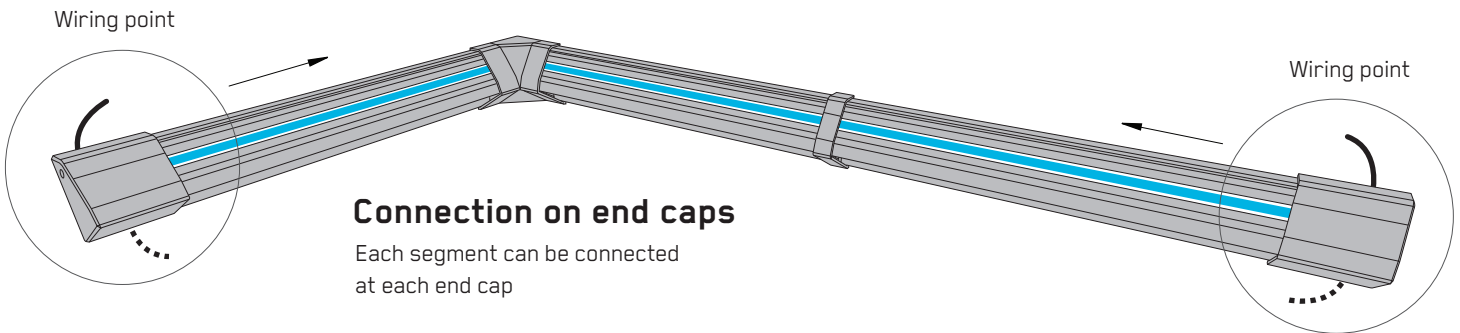

Connection on end caps

Each segment can be connected at each end cap

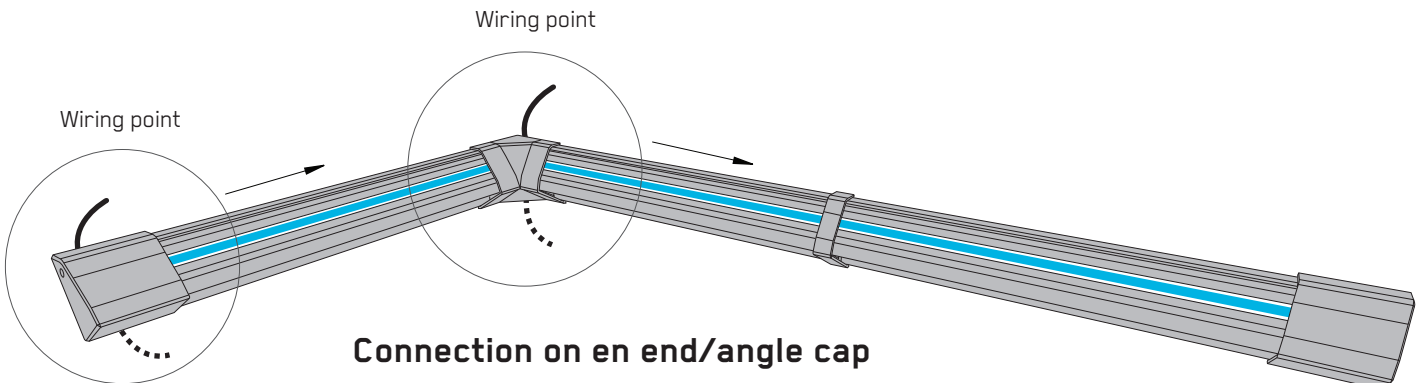

Connection on en end/angle cap

One segment connected at one en cap and the other at the angle cap

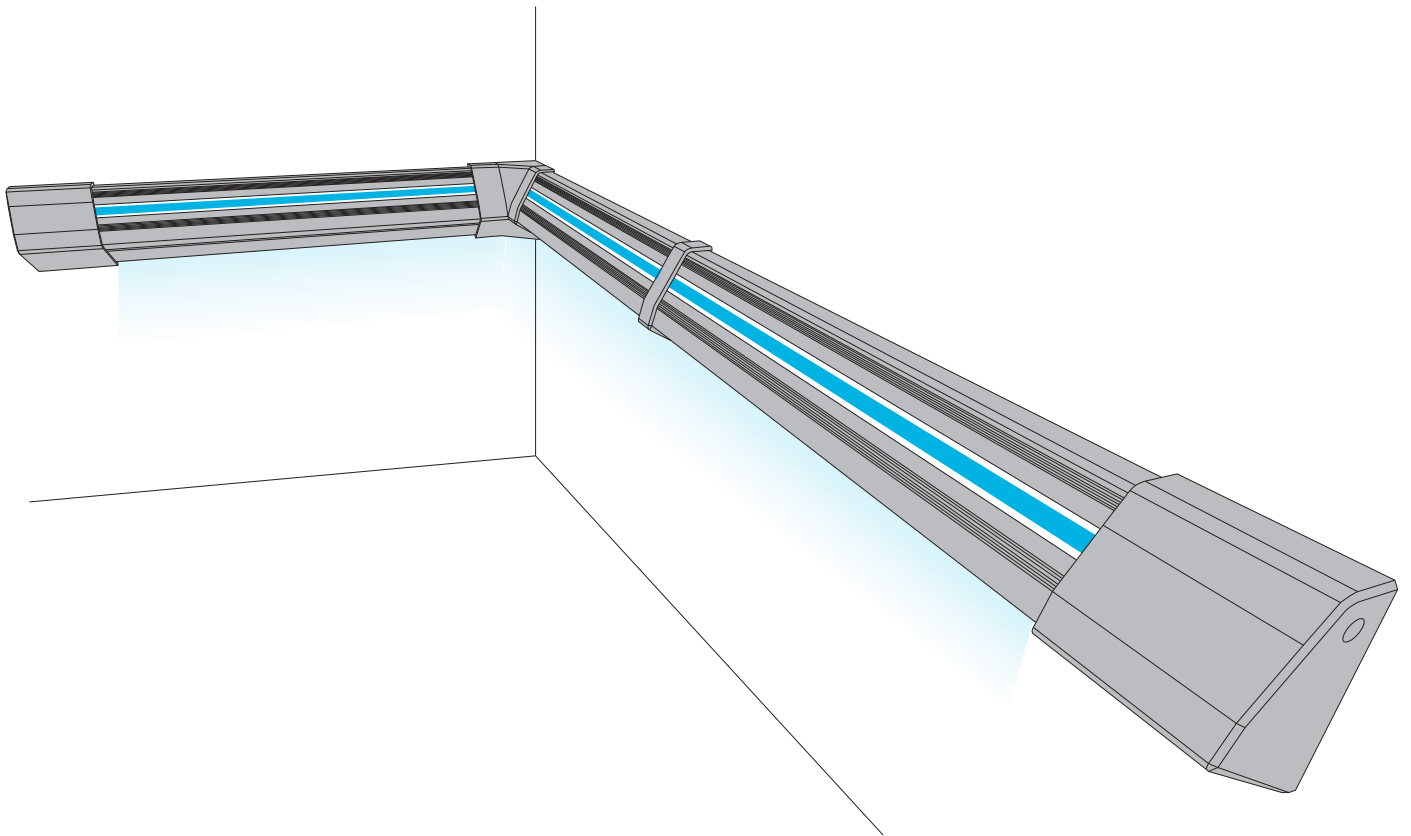

LIGHTING
LED OPTIONS





Item # _____

Project _____

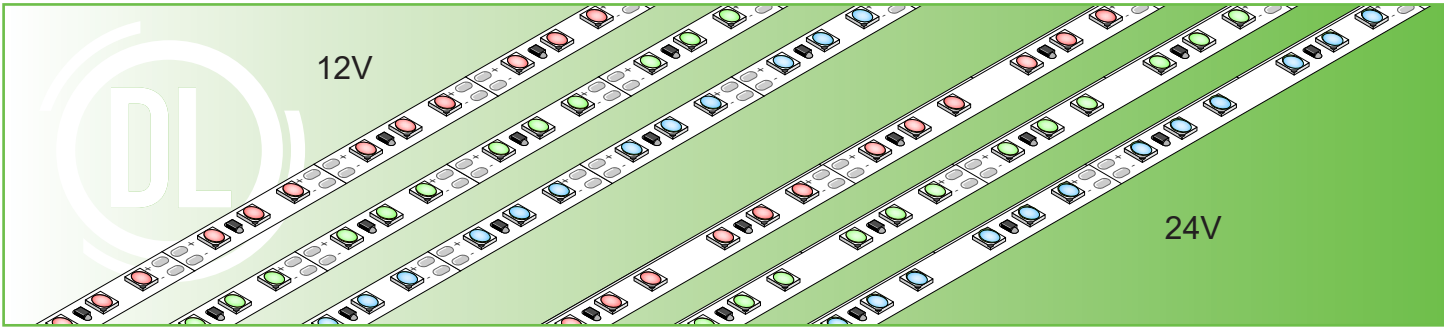

		DI-12V-BLC	DI-24V-BLC
Voltage		12VDC	24VDC
Wattage		2.93/ft	2.93/ft
Cut Points		1 in.	2 in.
Lumens	Red	29/ft	89/ft
	Green	187/ft	192/ft
	Blue	43/ft	45/ft
Max. Run¹		20 ft.	40 ft.
LED Chips		36/ft	36/ft
Colors		Red, Green, Blue	
Dimmable		Yes	
Dimensions		0.32 x 0.1 in. (W x H)	
Environment²		Indoor / Damp Location	
Certification		UL Listed 2108	
Warranty		12-Year Warranty	

SKU Builder

DI	-	<input type="text"/>	-	BLC	-	<input type="text"/>	-	<input type="text"/>
		Voltage		Model		Color		Length
		12V				RD		016
		24V				GR		100
						BL		

Example: DI-12V-BLCGR-016 = Diode LED, 12 Volt, BLAZE™ COLORS, Green, 16.4 foot spool.

SPECIFICATIONS

- LED Chip Type: 2835 GuangMu Chip
- LED Chip Beam Angle: 120°
- Mounting³: 3M™ 55236 Adhesive Backing
- Connections⁴: 2.5 inch hard-wire lead: 20/2 AWG
- Ambient Temp⁵: -4 ~ 122°F (-20 ~ 50°C)
- Operating Temp⁶: -4 ~ 176°F (-20 ~ 80°C)

COMPLIANCE & REGULATORY APPROVALS

Safety

- UL Listed 2108 Low Voltage Lighting System / Low Voltage Luminaire. UL 1598 / CSA 250.0-08, UL 8750. UL 879 / CAN/CSA-C22.2 no. 207-M89. Certified for United States and Canada. File # E469769.
- UL Listed Field Cuttable.
- UL Recognized Component - Sign Accessories. Available in UL Sign Components Manual (SAMS Manual). File # E469770.
- CE & EMC Compliant: Verification No. GZEM141200683705V
- Approved for storage areas of clothes closets per NEC 410.16.A.3 and 410.16.C.5

Environmental

- RoHS Compliant: Verification No. CANEC1610091501

Performance

- LED chip data measured in accordance to IES LM-80-08.
- Photometric & Colorimetry data measured in accordance to IES LM-79-08, in Elemental LED's Innovation Lab.

ADDITIONAL ACCESSORIES

Accessories listed below fully support our LED Light Tape product line.

TERMINAL BLOCK CONNECTOR

Tape Light Connector

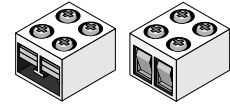

CLICKTIGHT® Tape Light Connectors

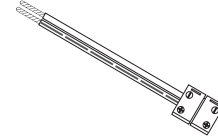

TAPEGUARD® LED Light Cover

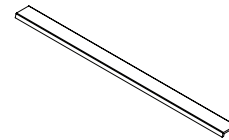

CHROMAPATH® Builder Channels

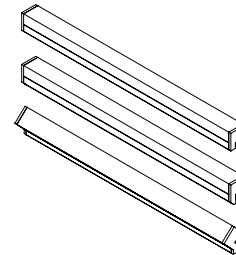

CHROMAPATH® Bundle Channels

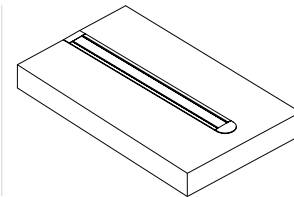

1. Each maximum run requires a dedicated power feed from the driver. Do not extend beyond the recommended maximum run length.
2. Do not install in environment where LED chips are exposed to direct sunlight as damage to the phosphor will occur. NEC definition of damp location: Locations protected from weather and not subject to saturation with water or other liquids but subject to moderate degrees of moisture. Examples of such locations include partially protected locations under canopies, marquees, roofed open porches, and like locations, and interior locations subject to moderate degrees of moisture, such as some basements, some barns, and some cold-storage warehouses.
3. Ideal tape application temperature range is 70°F to 100°F (21°C to 38°C). Initial tape application to surfaces at temperatures below 50°F (10°C) is not recommended because the adhesive becomes too firm to adhere readily. However, once properly applied, low temperature holding is generally satisfactory.
4. Wire leads and accessories are not rated for in-wall installation unless otherwise noted. Attached wire leads and connections are field-cuttable.
5. Do not install product in an environment outside the listed ambient temperature. Exceeding the maximum ambient temperature may damage LED chips, reduce the total lamp life, lumen output, and/or adversely impact color consistency.
6. Operating temperature is measured according to the minimum and maximum ambient temperature environment.

MECHANICAL DIAGRAM

BLAZE™ COLORS 12V

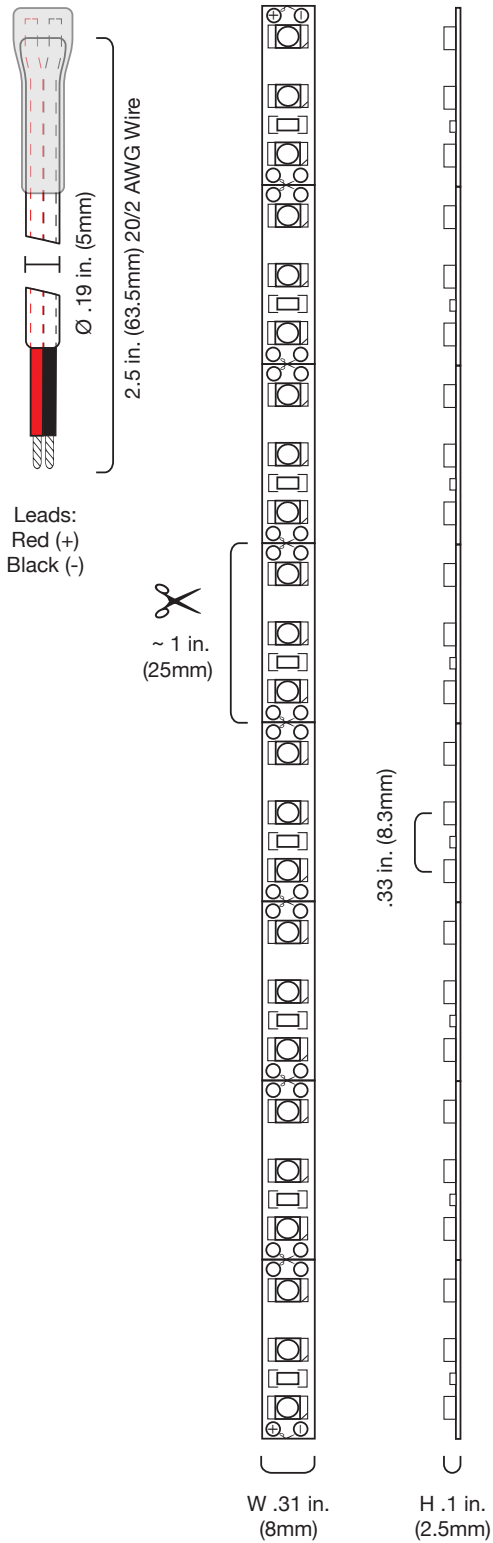

BLAZE™ COLORS 24V

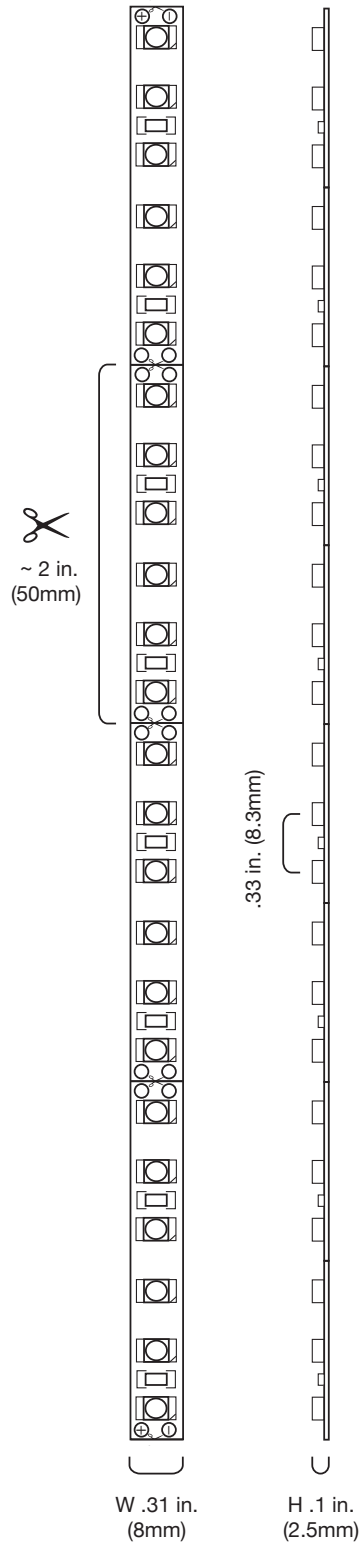

LED DRIVERS (Required)

The following Listed LED Drivers are recommended to meet NEC code when installed according to specifications.

SWITCHEX® DRIVER + DIMMER SWITCH

SWITCHEX combines an LED driver and LED dimmer switch into a single integrated unit. Fits into standard switch boxes.

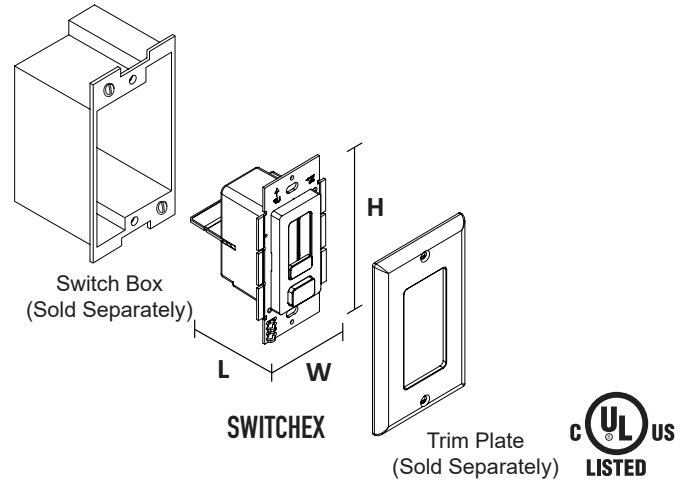
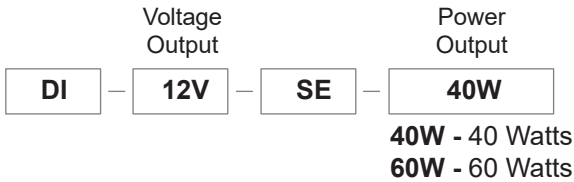

SKU	L - LENGTH	W - WIDTH	H - HEIGHT
DI-12V-SE-40W			
DI-12V-SE-60W			

Fits in Standard Switch Box

LO-PRO® JUNCTION BOX & DRIVER COMBO - 12V CONSTANT VOLTAGE LED DRIVER

Use Constant Voltage Drivers to power your low voltage tape light. Compatible with Standard 120VAC On/Off Switches, REIGN® 12-24V Low Voltage Dimmers, TOUCHDIAL™ Control System, DMX Decoders, and PWM Controls.

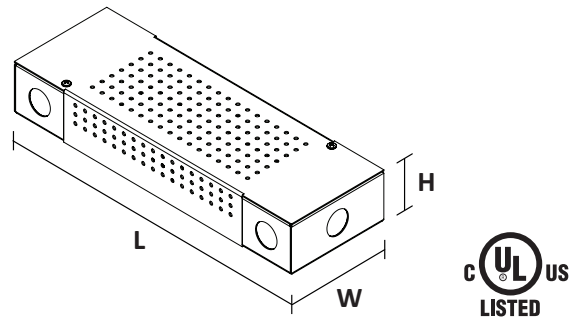
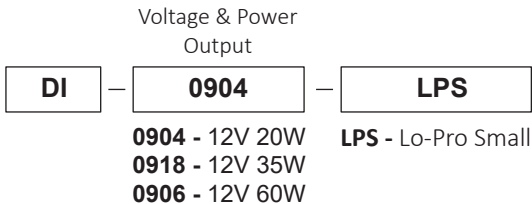

SKU	L - LENGTH	W - WIDTH	H - HEIGHT
DI-0904-LPS			
DI-0918-LPS	11.25 in.	3.75 in.	1.90 in.
DI-0906-LPS			

LO-PRO® JUNCTION BOX & DRIVER COMBO - 12V COMMERCIAL GRADE 0-10V LED DIMMABLE DRIVER

Compatible with 0-10V controls and dimmer systems.

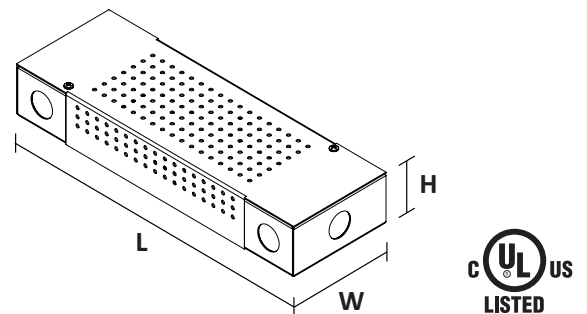
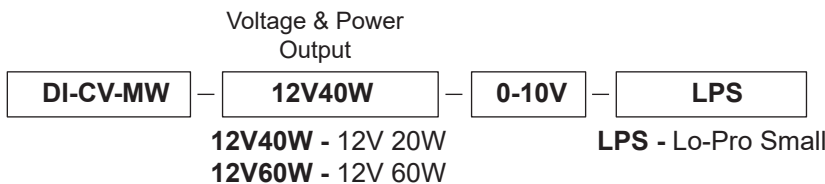

SKU	L - LENGTH	W - WIDTH	H - HEIGHT
DI-CV-MW-12V40W-0-10V-LPS			
DI-CV-MW-12V60W-0-10V-LPS	11.25 in.	3.75 in.	1.90 in.

The following Listed LED Drivers are recommended to meet NEC code when installed according to specifications.

OMNIDRIVE® 2 ELECTRONIC DIMMABLE LED DRIVER

OMNIDRIVE 2 features a zero minimum load and 100-5% dimming range. Compatible with Forward Phase and Reverse Phase Dimmers.

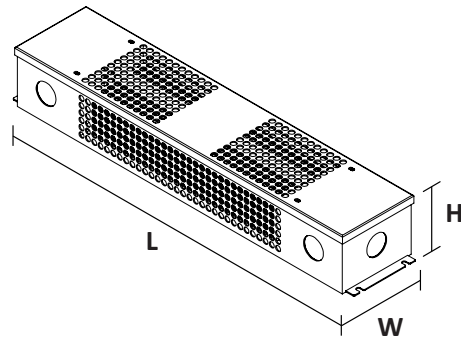
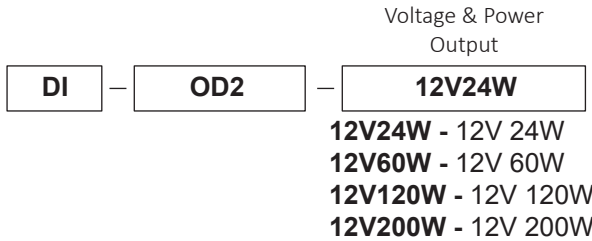

SKU	L - LENGTH	W - WIDTH	H - HEIGHT
DI-OD2-12V24W	13.75 in.	3.00 in.	1.60 in.
DI-OD2-12V60W	13.75 in.	3.00 in.	1.60 in.
DI-OD2-12V120W	15.00 in.	3.10 in.	2.40 in.
DI-OD2-12V200W	16.10 in.	3.40 in.	2.40 in.

LUTRON® Hi-lume 1% LED DIMMABLE DRIVER

Hi-lume 1% LED driver has a minimum load of 5W and Dims from 100-1%.

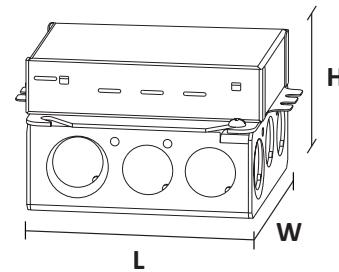
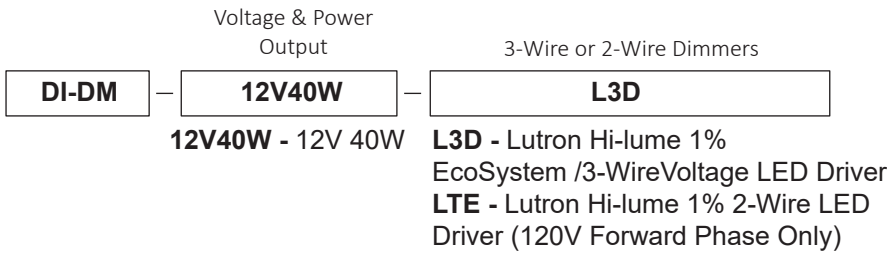

SKU	L - LENGTH	W - WIDTH	H - HEIGHT
DI-DM-12V40W-L3D	4.89 in.	4.00 in.	2.62 in.
DDI-DM-12V40W-LTE			

LUTRON® Hi-lume Premier 0.1% LED DIMMABLE DRIVER

Hi-Lume Premier 0.1% LED driver has a minimum load of 5W and Dims from 100-0.1%.

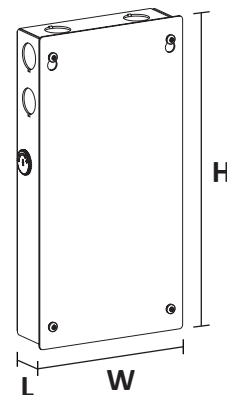
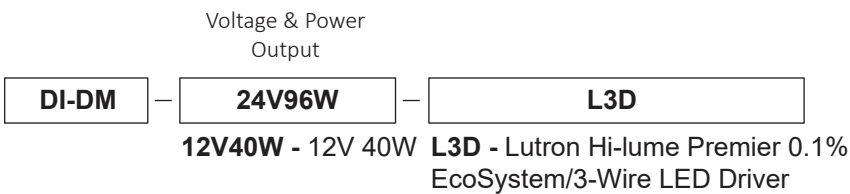

SKU	L - LENGTH	W - WIDTH	H - HEIGHT
DI-DM-24V96W-L3D	5.50 in.	2.20 in.	10.50 in.

LED DRIVERS (Required)

SPECIFICATION SHEET

The following Listed LED Drivers are recommended for compatibility and to meet NEC code when installed according to specifications.

SWITCHEX® DRIVER + DIMMER SWITCH

SWITCHEX combines an LED driver and LED dimmer switch into a single integrated unit. Fits into standard switch boxes.



SKU	L - LENGTH	W - WIDTH	H - HEIGHT
DI-24V-SE-60W	1.40 in.	2.10 in.	4.10 in.
DI-24V-SE-100W	1.40 in.	2.10 in.	4.10 in.

Fits in Standard Switch Box

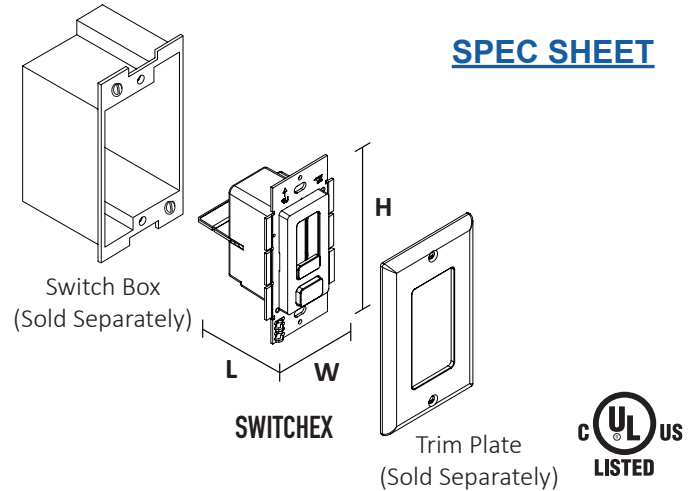

LO-PRO® JUNCTION BOX & DRIVER COMBO - 24V CONSTANT VOLTAGE LED DRIVER

Use Constant Voltage Drivers to power your lighting system. Compatible with Standard 120VAC On/Off Switches, REIGN® Low Voltage Dimmers, TOUCHDIAL™ Control System, DMX Decoders, and PWM Controls.

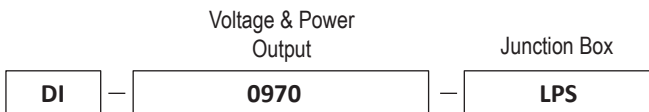

SKU	L - LENGTH	W - WIDTH	H - HEIGHT
DI-0970-LPS	11.25 in.	3.75 in.	1.90 in.
DI-CV-MW24V60W-277-LPS	11.25 in.	3.75 in.	1.90 in.
DI-CV-MW24V90W-277-LPS	11.25 in.	3.75 in.	1.90 in.
DI-0954-LPL	13.5 in.	4.5 in.	2.37 in.

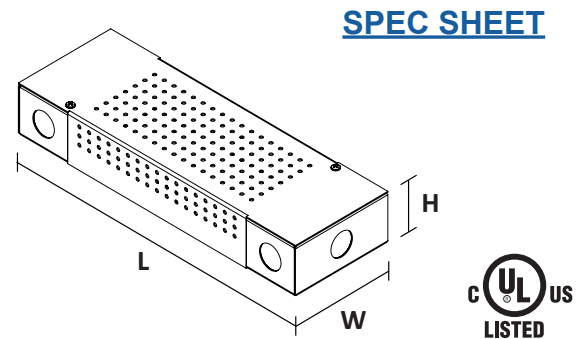

LO-PRO® JUNCTION BOX & DRIVER COMBO - 24V COMMERCIAL GRADE 0-10V LED DIMMABLE DRIVER

Compatible with 0-10V controls and dimming systems.

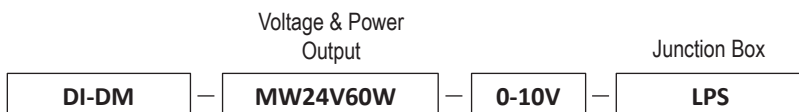

SKU	L - LENGTH	W - WIDTH	H - HEIGHT
DI-DM-MW-24V60W-0-10V-LPS	11.25 in.	3.75 in.	1.90 in.
DI-DM-MW-24V90W-0-10V-LPL	13.5 in.	4.5 in.	2.37 in.

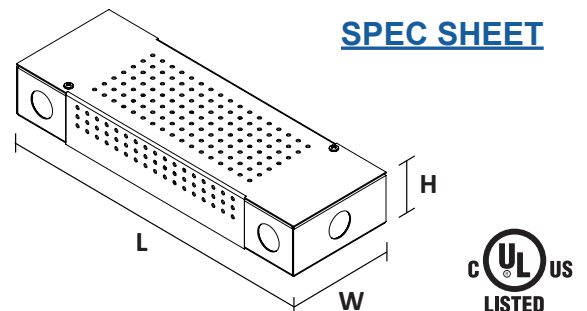

The following Listed LED Drivers are recommended for compatibility and to meet NEC code when installed according to specifications.

OMNIDRIVE® 2 ELECTRONIC DIMMABLE LED DRIVER

OMNIDRIVE 2 features a zero minimum load and 100-5% dimming range. Compatible with Forward Phase and Reverse Phase Dimmers.

Voltage & Power Output



SKU	L - LENGTH	W - WIDTH	H - HEIGHT
DI-OD2-24V24W	13.75 in.	3.00 in.	1.60 in.
DI-OD2-24V60W	13.75 in.	3.00 in.	1.60 in.
DI-OD2-24V96W	15.00 in.	3.10 in.	2.40 in.
DI-OD2-24V120W	15.00 in.	3.10 in.	2.40 in.
DI-OD2-24V200W	16.10 in.	3.40 in.	2.40 in.

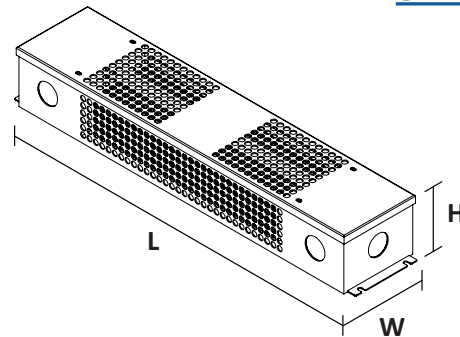

[SPEC SHEET](#)



LUTRON® Hi-lume 1% LED DIMMABLE DRIVER

Hi-lume 1% LED Driver has a minimum load of 5W and dims from 100-1%.

Voltage & Power Output

3-Wire or 2-Wire Dimmers



SKU	L - LENGTH	W - WIDTH	H - HEIGHT
DI-DM-24V40W-L3D	4.89 in.	4.00 in.	2.62 in.
DI-DM-24V40W-LTE			

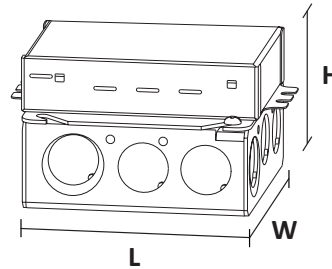

[L3D SPEC SHEET](#)

[LTE SPEC SHEET](#)



LUTRON® Hi-lume Premier 0.1% LED DIMMABLE DRIVER

Hi-Lume Premier 0.1% LED Driver has a minimum load of 5W and dims from 100-0.1%.

Voltage & Power Output



SKU	L - LENGTH	W - WIDTH	H - HEIGHT
DI-DM-24V96W-L3D	5.50 in.	2.20 in.	10.50 in.

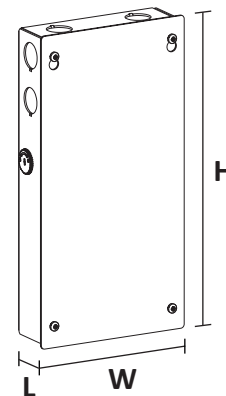

[SPEC SHEET](#)



The following Listed LED Drivers are recommended to meet NEC code when installed according to specifications.

VLM SERIES CONSTANT VOLTAGE DRIVER

Use Constant Voltage Drivers to power your low voltage tape light. Compatible with Standard 120VAC On/Off Switches, REIGN® 12-24V Low Voltage Dimmers, TOUCHDIAL™ Control System, DMX Decoders, and PWM Controls.

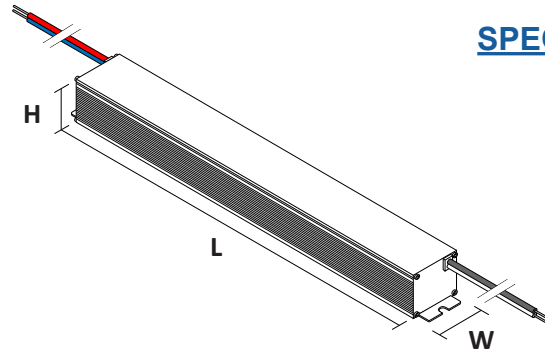
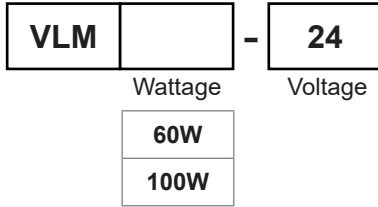

[SPEC SHEET](#)

SKU	L - LENGTH	W - WIDTH	H - HEIGHT
VLM60W-24	5.1 in.	.75 in.	.77 in.
VLM100W-24	5.38 in.	1 in.	.77 in.





BLAZE™ COLORS LED Light Tape

ADDITIONAL INFORMATION

SPECIFICATION SHEET

- LOW VOLTAGE LED TAPE LIGHT Installation Guide

SAFETY / WARNINGS / DISCLOSURES

1. Install in accordance with national and local electrical code regulations.
2. This product is intended to be installed and serviced by a qualified, licensed electrician.
3. Only install with a Class 2 DC Constant Voltage LED driver.
4. Only use copper wiring. Use wires rated for at least 176°F (80°C) and certified for use with external connection of electrical equipment.
5. Each maximum run requires a dedicated power feed from the driver. Do not extend beyond the recommended maximum run length.
6. Tape light, attached wire leads, and additional extension cables, connectors, etc., are not rated for in-wall installation unless otherwise noted. Tape light and attached wire leads are field-cuttable.
7. Ensure applicable wire is installed between driver, fixture, and any controls in-between. When choosing wire, factor in voltage drop, amperage rating, and type (in-wall rated, wet location rated, etc.). Inadequate wire installation could overheat wires, and cause fire.
8. Do not install in environment where LED chips are exposed to direct sunlight as damage to the phosphor will occur.
9. Do not install in environment where excessive heat may exist (ex. close proximity to fireplace, etc.) See Ambient Temperature ratings
10. Do not install indoor LED tape light products in outdoor / wet location environments. Only wet location tape light models are rated for outdoor / wet locations.
11. Do not modify product beyond instructions or warranty will be void.
12. Tape light must be handled with care. Excessive handling, bending, and pressure may damage the product, voiding the warranty.
13. Actual color may vary from what is pictured on this sheet and other print materials due to the limitations of photographic processes.
14. We reserve the right to modify and improve the design of our fixtures without prior notice. We cannot guarantee to match existing installed fixtures for subsequent orders or replacements in regards to product appearance, CCT, or lumen output.

DMX 4-CHANNEL DECODER



INSTALLATION GUIDE

SAFETY & WARNINGS

1. Install in accordance with national and local electrical code regulations.
2. This product is intended to be installed and serviced by a qualified, licensed electrician.
3. DO NOT connect directly to high voltage power. Install with a compatible Class 2 constant voltage LED driver (power supply).
4. This product is rated for indoor installation and is not protected against moisture.
5. Install appropriately rated wire between driver, decoder, and fixture. When choosing wire, factor in voltage drop, amperage rating, and type (in-wall rated, etc.) Inadequate wire installation may cause fire.
6. Do not modify or disassemble product beyond instructions or warranty will be void.

MAXIMUM DAISY-CHAIN DMX DECODERS

A maximum of 10x DMX Decoders may be connected together via RJ45 DMX Connection Ports. DMX signal may be extended further by installing a DMX 8-Way Splitter (DI-1804) after the 10th DMX Decoder.

QUICK SPECS / MODELS

	Input	Output	Max Load
DI-1810 (also DI-1918)	12 - 24VDC	12 - 24VDC	4CH x 5A 4CH x 96W (12V) 4CH x 192W (24V)

INSTALLATION

1 TURN POWER OFF AT CIRCUIT BREAKER



SHOCK HAZARD! May result in serious injury or death.
Turn power OFF at circuit breaker prior to installation.

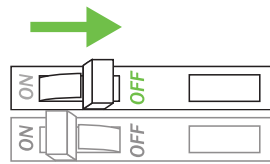

2 DETERMINE LOCATION TO INSTALL COMPONENTS

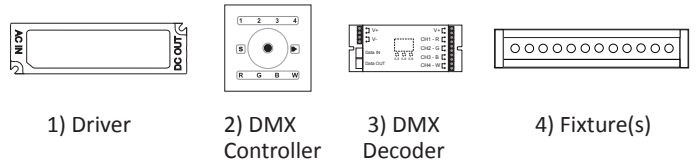

3 CONNECT DECODER TO DRIVER. ATTACH LED FIXTURE. ONLY USE COPPER WIRING.

Reference SYSTEM DIAGRAM located further in guide for visual.

4 CONNECT DECODER TO MASTER DMX CONTROLLER.

5 INSTALL ADDITIONAL COMPONENTS, VERIFY CONNECTIONS, TURN MAIN POWER ON AT BREAKER.

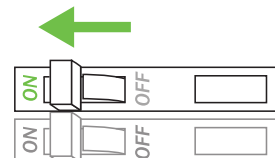

OPERATION

DMX START CHANNEL DISPLAY



Adjust the following settings with the DMX Start Channel Display (Fig. 1.):

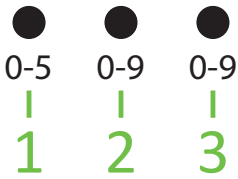

- a. DMX Address
- b. Output Channels (professional use only)
- c. PWM Frequency (professional use only)

SETTING THE DMX ADDRESS

Use the 3 buttons of the DMX start channel to adjust the values of the DMX address. The decoder will control up to 512 channels.

- a. To set the DMX address, press and hold 'button 1' for 2 seconds until numbers on display flash.
- b. Select an address based on the functionality of the Master DMX Controller (see controller installation guide). Once an address is selected, the remaining 3 channels will be utilized digitally. For example, if the decoder is addressed to 001 on the display then CH1 – 001, CH2 – 002, CH3 – 003, CH4 – 004.
- c. Once display stops flashing, DMX address is set.

OPERATION (PROFESSIONAL USE ONLY)

Diode LED strongly recommends only professional DMX installers utilize the following settings. All standard DMX applications specified by Diode LED do not require these settings to be adjusted.

SETTING DMX CHANNELS

The DMX channels can be adjusted, which allows the user to conserve DMX addresses that may be wasted when programming a large DMX universe.

The factory default is 4cH: 4 channels (address 001 - 004) as highlighted in the chart below. Charts have also been provided for 1cH, 2cH, and 3cH settings.

4cH (001 - 004)

Channel	Address
CH1	001
CH2	002
CH3	003
CH4	004

1cH (001 Only)

Channel	Address
CH1	001
CH2	001
CH3	001
CH4	001

2cH (001 - 002 Only)

Channel	Address
CH1	001
CH2	002
CH3	001
CH4	002

3cH (001 - 003 Only)

Channel	Address
CH1	001
CH2	002
CH3	003
CH4	001



Fig. 2



Fig. 3

To change channel setting:

- a. Press and hold 'button 2 and 3' simultaneously for 2 seconds until 'cH' flashes on display (Fig. 2).
- b. Press 'button 1' to choose 1, 2, 3, or 4 channel outputs (Fig. 3).
- c. Press and hold any button for >2 seconds to set channel output.

SETTING PWM FREQUENCY & DIMMING TYPE

The PWM frequency & dimming type can be adjusted for special applications.

RGB & RGBW SETTINGS

RGB & RGBW installations will only operate correctly with consistent color output when programmed to P1 (1500Hz PWM OUTPUT) and c2 (LINEAR DIMMING).

PWM & DIM (P_c)

PWM Output (P)	Dimming Output (c)
1 = 1500Hz	1 = Logarithmic Dimming
2 = 200 Hz	2 = Linear Dimming



Fig. 4



RGB/RGBW
REQUIRED SETTING

To change PWM or DIM:

- a. Press and hold 'button 1 and 3' simultaneously for 2 seconds until 'P_c' flashes on display (Fig. 4).
- b. Press 'button 1' to choose PWM output type.
- c. Press 'button 3' to choose Dimming type.
- d. Once display stops flashing, PWM & DIM is set.

SYSTEM DIAGRAM

The following diagram is provided as an example system design. CAT5 (RJ45 connections) data cables are the most cost-effective solution for transmitting DMX-512 signals. XLR-3 cables may also be installed but require an additional adapter for connecting to DMX decoders.

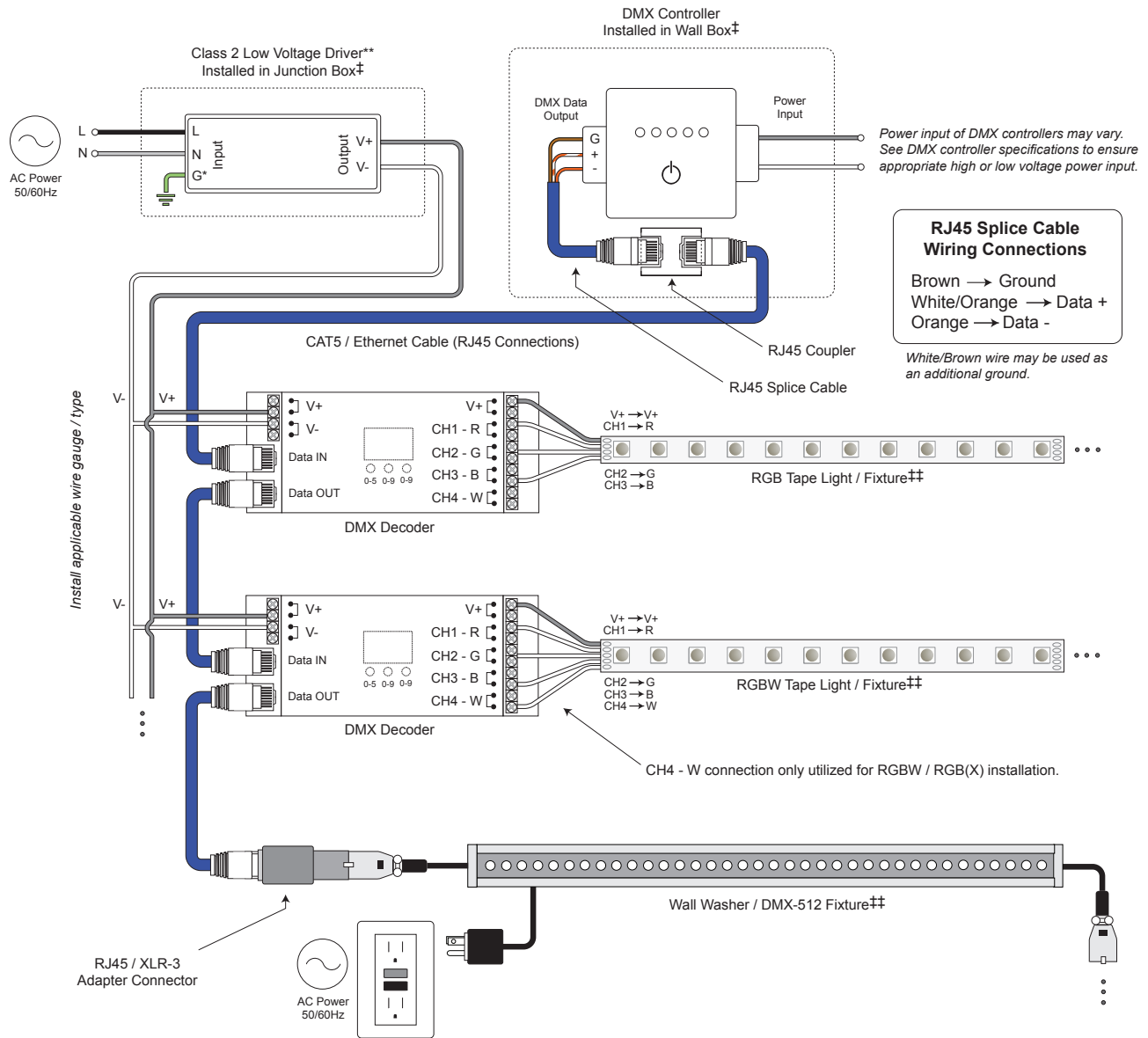

MAXIMUM DAISY-CHAIN DMX DECODERS
A maximum of 10x DMX Decoders may be connected together via RJ45 DMX Connection Ports. DMX signal may be extended further by installing a DMX 8-Way Splitter (DI-1804) after the 10th DMX Decoder.

* Driver may not require a fault ground connection. Refer to driver specifications for additional information.

** Install a compatible Class 2 constant voltage driver. It is recommended to load the driver no more than 80% its labeled rating for maximum longevity.

‡ Refer to driver specifications for a compatible junction box.

‡‡ See fixture specifications for maximum series run limits.

TROUBLESHOOTING

Symptom	Common Cause
Fixture responding incorrectly and/or flickering	• Incorrect wiring. Reversing Data + and Data - will cause lights to flicker.
	• Incorrect voltage pairing of driver and fixture. (12V & 12V, or 24V and 24V)
	• Ensure compatible constant voltage driver is installed.
Cannot change DMX address	• Check connections of additional components.
	• Hold in button '0-5' for 3 seconds until display flashes continuously, then set address.

VOLTAGE DROP CHARTS

For best performance and lumen output, ensure proper wire gauge is installed to compensate for voltage drop of low voltage circuits.

Example: 12V Voltage Drop & Wire Length Distance Chart

Wire Gauge	10 W .83 A	20 W 1.7 A	30 W 2.5 A	40 W 3.3 A	50 W 2.1 A	60 W 4.2 A
18 AWG	34 ft.	17 ft.	11 ft.	8 ft.	6 ft.	5 ft.
16 AWG	54 ft.	27 ft.	18 ft.	13 ft.	10 ft.	9 ft.
14 AWG	86 ft.	43 ft.	29 ft.	21 ft.	17 ft.	14 ft.
12 AWG	134 ft.	68 ft.	45 ft.	34 ft.	27 ft.	22 ft.
10 AWG	199 ft.	99 ft.	66 ft.	49 ft.	39 ft.	33 ft.



1 Determine load size. Let's assume load is 55 W. Round up to nearest load.



2 Determine distance from driver to load. Let's assume the distance is 20 ft.



3 It's recommended to install 12 AWG to eliminate excess voltage drop.

12V Voltage Drop & Wire Length Distance Chart

Wire Gauge	10 W .83 A	20 W 1.7 A	30 W 2.5 A	40 W 3.3 A	50 W 2.1 A	60 W 4.2 A
18 AWG	34 ft.	17 ft.	11 ft.	8 ft.	6 ft.	5 ft.
16 AWG	54 ft.	27 ft.	18 ft.	13 ft.	10 ft.	9 ft.
14 AWG	86 ft.	43 ft.	29 ft.	21 ft.	17 ft.	14 ft.
12 AWG	134 ft.	68 ft.	45 ft.	34 ft.	27 ft.	22 ft.
10 AWG	199 ft.	99 ft.	66 ft.	49 ft.	39 ft.	33 ft.

24V Voltage Drop & Wire Length Distance Chart

Wire Gauge	10 W .42 A	20 W .83 A	30 W 1.3 A	40 W 1.7 A	50 W 2.1 A	60 W 2.5 A	70 W 2.9 A	80 W 3.3 A	100 W 4.2 A
18 AWG	134 ft.	68 ft.	45 ft.	33 ft.	27 ft.	22 ft.	19 ft.	17 ft.	14 ft.
16 AWG	215 ft.	109 ft.	72 ft.	54 ft.	43 ft.	36 ft.	31 ft.	27 ft.	22 ft.
14 AWG	345 ft.	174 ft.	115 ft.	86 ft.	69 ft.	57 ft.	49 ft.	43 ft.	36 ft.
12 AWG	539 ft.	272 ft.	181 ft.	135 ft.	108 ft.	90 ft.	77 ft.	68 ft.	56 ft.
10 AWG	784 ft.	397 ft.	263 ft.	197 ft.	158 ft.	131 ft.	112 ft.	98 ft.	82 ft.

LM-79 Test Report

Relevant Standards

IES LM-79-2008
IES TM-30-2015
CIE 13.3-1995

Product SKU

BLAZE™ 100 LED Tape Light - DI-12V-BLBSC1-30-***

Test Conditions

Test Temperature: 26.5 °C
Luminaire Sample Length: 12 in.
Power Supply: Agilent E3634A DC Power Supply
Voltage: 12 VDC
Current: 0.114 A
Power Consumption: 1.368 W

Test Date

7/3/2018

Prepared By

Rachel Backlund

Rachel Backlund

Approved By

Olivia M. Tanguileg

Olivia Tanguileg, Electrical Engineer

The results contained in this report pertain only to the tested sample.
Photometric & Colorimetry data measured in accordance to IES LM-79-2008 standards, at the Elemental LED, Inc. Innovation Lab.

Integrating Sphere Test

SUMMARY OF RESULTS

Metric	Test	Reference	Notes	Metric	Test	Reference	Notes
R_f	91	100	IES TM-30-15 Fidelity Index	CCT	3032	3031	Correlated Color Temperature
R_g	99	100	IES TM-30-15 Gamut Index	D_{uv}	0.0015	0.0000	Distance from the blackbody locus
R_a (CRI)	92	100	CIE Test Color Method General Index	x	0.4369	0.4347	CIE 1931 chromaticity coordinate
R_9	64	100	CIE Test Color Method Sample Nine Score	y	0.4079	0.4033	CIE 1931 chromaticity coordinate
LER	287	164	Luminous Efficacy of Radiation	u	0.2489	0.2495	CIE 1960 chromaticity coordinate
Lumens	116	1852	Luminous Flux	v	0.3486	0.3472	CIE 1960 chromaticity coordinate
$R_{f,skin}$	95	100	Average of CES15 and CES18 (skin)	u'	0.2489	0.2495	CIE 1976 chromaticity coordinate
				v'	0.5229	0.5207	CIE 1976 chromaticity coordinate

COLOR RENDERING INDEX

R 1	R 2	R 3	R 4	R 5	R 6	R 7	R 8	R 9	R 10	R 11	R 12	R 13	R 14
92.1	94.3	95.0	92.7	91.1	92.1	94.5	85.1	63.9	85.4	92.4	76.4	92.4	96.4

SOURCE PROPERTIES

SOURCE CHROMATICITY COMPARISON

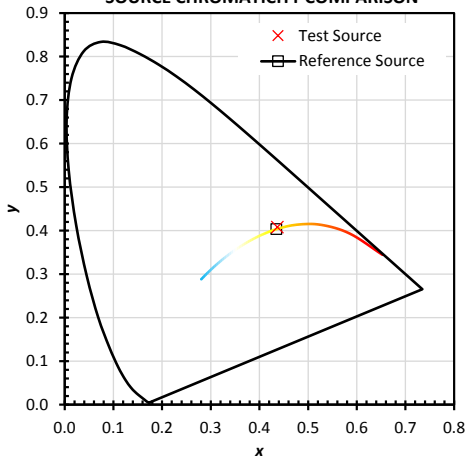

This chart plots the chromaticity of the test and reference sources in the CIE 1931 chromaticity

SPECTRAL POWER DISTRIBUTION COMPARISON

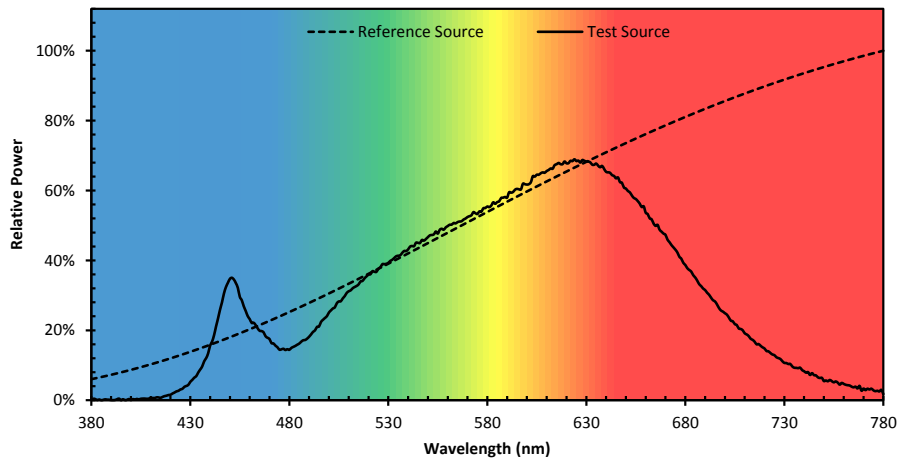

This chart displays the spectral power distributions for the test and reference source. Each SPD has been normalized so that the maximum values is 100%.

GENERAL COLOR RENDITION

CES CHROMATICITY COMPARISON

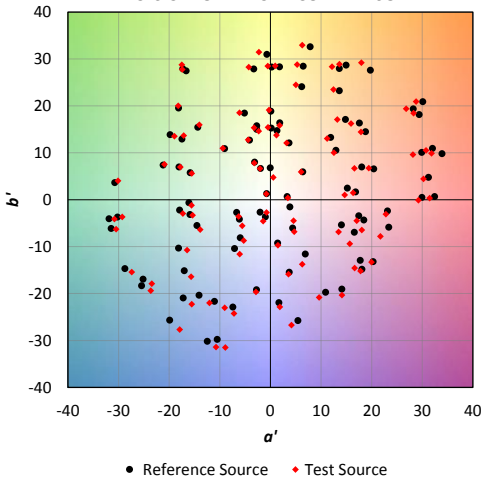

This plot shows the shift in chromaticity for each individual CES.

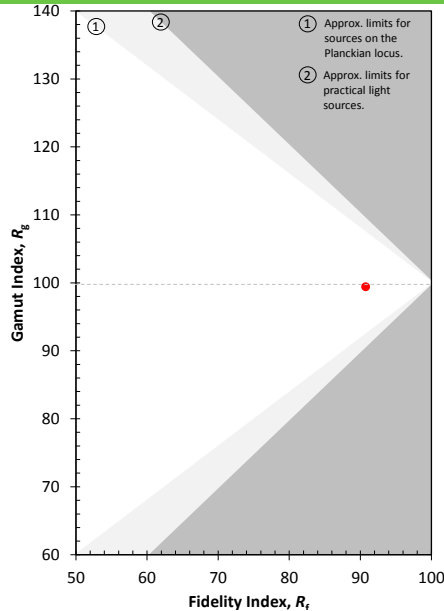

This plot shows the R_f and R_g values relative to possible values.

COLOR VECTOR GRAPHIC

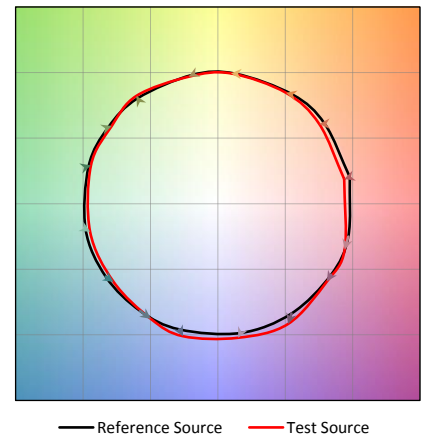

This plot shows the average chromaticity shift for the samples within each of 16 hue bins. The values are normalized so that the reference is a circle.

COLOR SAMPLE COMPARISON (APPROXIMATION)

CES 1 Type C	CES 2 Type C	CES 3 Type A	CES 4 Type A	CES 5 Type D	CES 6 Type C	CES 7 Type E	CES 8 Type D
CES 9 Type F	CES 10 Type G	CES 11 Type C	CES 12 Type A	CES 13 Type F	CES 14 Type E	CES 15 Type B	CES 16 Type C
CES 17 Type C	CES 18 Type B	CES 19 Type E	CES 20 Type F	CES 21 Type D	CES 22 Type D	CES 23 Type G	CES 24 Type E
CES 25 Type A	CES 26 Type C	CES 27 Type A	CES 28 Type G	CES 29 Type C	CES 30 Type A	CES 31 Type D	CES 32 Type C
CES 33 Type D	CES 34 Type G	CES 35 Type G	CES 36 Type A	CES 37 Type A	CES 38 Type A	CES 39 Type F	CES 40 Type F
CES 41 Type C	CES 42 Type F	CES 43 Type C	CES 44 Type F	CES 45 Type G	CES 46 Type E	CES 47 Type C	CES 48 Type D
CES 49 Type D	CES 50 Type F	CES 51 Type F	CES 52 Type F	CES 53 Type E	CES 54 Type F	CES 55 Type G	CES 56 Type G
CES 57 Type C	CES 58 Type D	CES 59 Type E	CES 60 Type G	CES 61 Type F	CES 62 Type C	CES 63 Type F	CES 64 Type E
CES 65 Type F	CES 66 Type E	CES 67 Type E	CES 68 Type F	CES 69 Type F	CES 70 Type F	CES 71 Type F	CES 72 Type F
CES 73 Type F	CES 74 Type C	CES 75 Type F	CES 76 Type F	CES 77 Type A	CES 78 Type F	CES 79 Type C	CES 80 Type G
CES 81 Type A	CES 82 Type C	CES 83 Type C	CES 84 Type F	CES 85 Type A	CES 86 Type C	CES 87 Type F	CES 88 Type F
CES 89 Type A	CES 90 Type E	CES 91 Type A	CES 92 Type A	CES 93 Type D	CES 94 Type C	CES 95 Type A	CES 96 Type A
CES 97 Type F	CES 98 Type A	CES 99 Type E					

NOTE: CES stands for "Color Evaluation Sample", these 99 samples are used in place of the 16 R values. The colors shown are approximate and depend on proper monitor calibration. Some colors may be outside of the gamut of the monitor, and will not be displayed accurately. For each sample, the color on the left represents the reference source, and the color on the right represents the test source.

Sample Type:

- A - Nature
- B - Skin
- C - Textiles
- D - Paints
- E - Plastic



Elemental



Competitor



COLOR RENDITION BY HUE

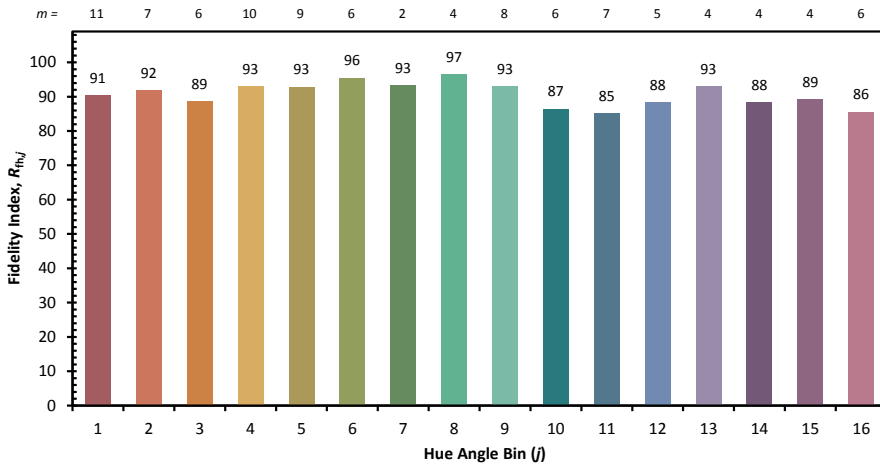

j	Hue Angle
1	0.0° - 22.5°
2	22.5° - 45.0°
3	45.0° - 67.5°
4	67.5° - 90.0°
5	90.0° - 112.5°
6	112.5° - 135.0°
7	135.0° - 157.5°
8	157.5° - 180.0°
9	180.0° - 202.5°
10	202.5° - 225.0°
11	225.0° - 247.5°
12	247.5° - 270.0°
13	270.0° - 292.5°
14	292.5° - 315.0°
15	315.0° - 337.5°
16	337.5° - 360.0°

This chart displays the average Fidelity Index for all samples within the hue bin. The number of samples per bin, which can vary based on the CCT used for the calculation, is shown at the top. The color of the bar is based on the average chromaticity under the 5000 K reference illuminant; the colors may not display accurately depending on the calibration of the monitor, and should be used for orientation only.

m = Samples per Angle Bin

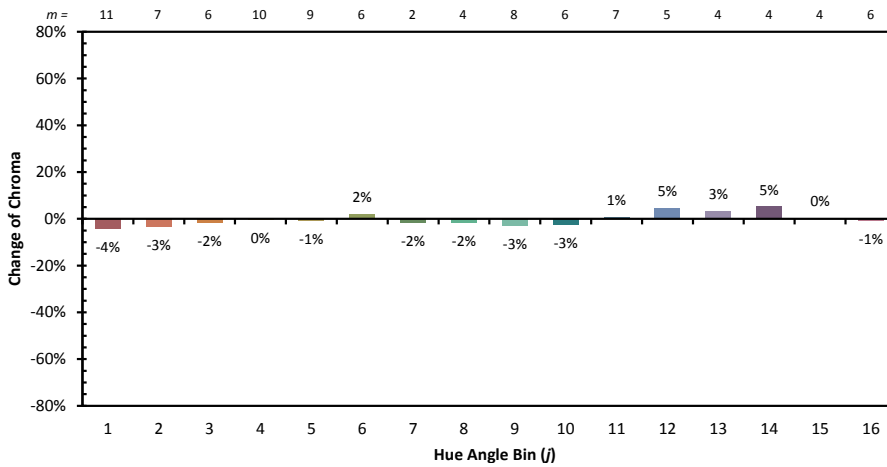

This chart displays the change in chroma for the average sample within each hue bin. The number of samples per bin, which can vary based on the CCT used for the calculation, is shown at the top. The color of the bar is based on the average chromaticity under the 5000 K reference illuminant; the colors may not display accurately depending on the calibration of the monitor, and should be used for orientation only.

COLOR FIDELITY BY SAMPLE

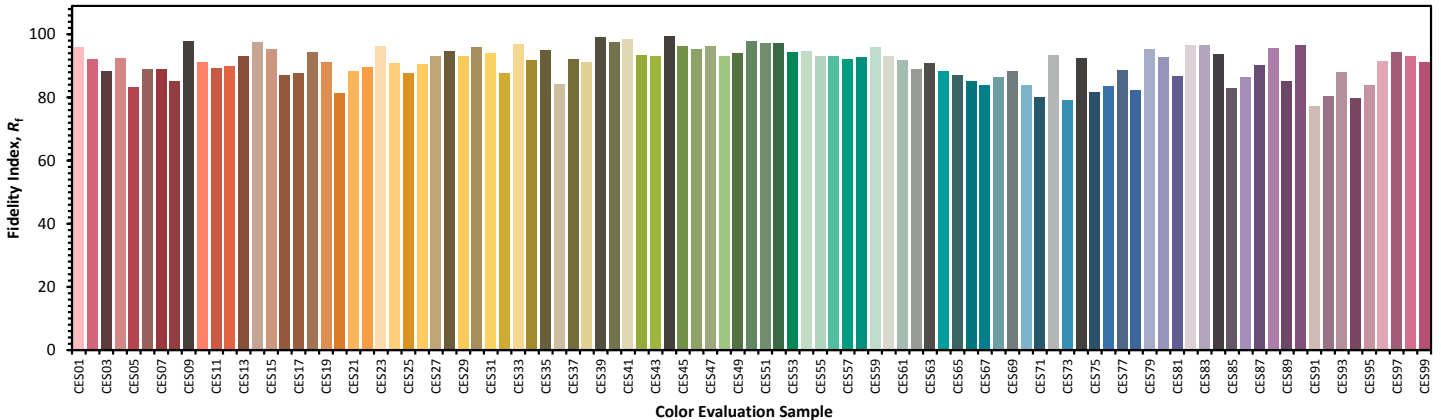

This chart displays the Fidelity Index for each of the 99 CES. The CES are arranged by their hue angle under the 5000 K reference source, which was also used to determine the color of each bar. The colors are approximate and depend on proper monitor calibration. Some colors may be outside of the gamut of the monitor, and will not be displayed accurately.

Goniophotometer Test

SUMMARY OF RESULTS

Luminaire: BLAZE™ 100 LED Tape Light
 SKU: DI-12V-BLBC1-30-***
 Luminous Flux: 119 Lumens
 Power Consumption: 1.368 Watts
 Efficacy: 87.0 Lumens/Watt
 Spacing Criterion (0-180): 1.28
 Spacing Criterion (90-270): 1.26

Graphs below are for reference, full IES files are available via request

DISTRIBUTION CHARTS AND TABLES

Zonal Lumen Data

Zone	Lumens	%Luminaire
0-20	15.27	12.80
0-30	32.45	27.20
0-40	53.24	44.70
0-60	94.38	79.20
0-80	117.09	98.30
0-90	119.14	100.00
20-40	37.97	31.90
20-50	59.60	50.00
40-70	55.82	46.90
60-80	22.71	19.10
70-80	8.03	6.70
80-90	2.04	1.70
90-180	0.00	0.00
0-180	119.14	100.00

Polar Candela Distribution

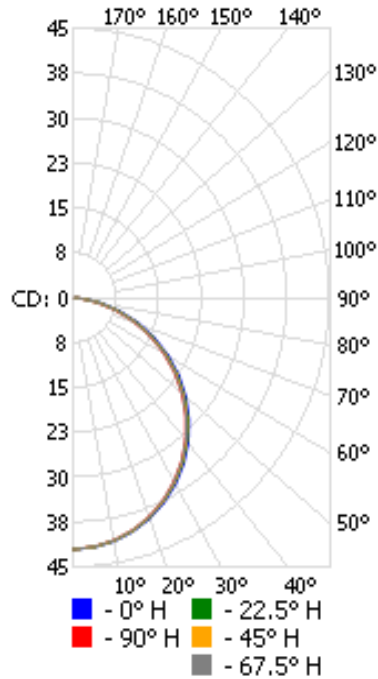

Illuminance at a Distance

Distance	Center Beam fc		Beam Width	
	Center Beam fc	Beam Width	Center Beam fc	Beam Width
1.5ft	18.6 fc	4.6 ft	4.4 ft	
3.0ft	4.65 fc	9.2 ft	8.9 ft	
4.5ft	2.07 fc	13.8 ft	13.3 ft	
6.0ft	1.16 fc	18.4 ft	17.8 ft	
7.5ft	0.74 fc	23.0 ft	22.2 ft	
9.0ft	0.52 fc	27.7 ft	26.7 ft	

■ Vert. Spread: 113.9°
■ Horiz. Spread: 112.0°



StepGuard[®]



LightTape[®]
INSIDE

Electro-Luminix Lighting Corporation

1320 N Arthur Ashe Blvd.
Richmond, Virginia 23230
U.S.A.

1.804.355.1692
stepguardteam@lighttape.com