

WallGuide™ Immersive

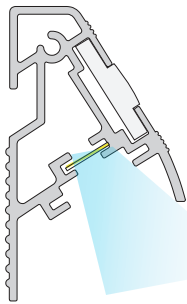

SG-WG-DL: Light Tape® shining down

Our WallGuide™ system is designed to be mounted on the wall to provide navigation illumination for entrance ways and stairs.

WallGuide™ with Light Tape® offers the perfect amount of light for navigation while preserving an immersive environment. With no glare or bounce off the carpet, the viewing screen is protected from the light source. The light illuminates the floor but not the venue.

The WallGuide™ design is recommended for mounting on walls in sections. Then feeding our Light Tape® in a channel specifically designed in long lengths of continuous illumination.

Design Features

- Profile arrives in sections up to 3 meters in length.
- Illuminated by one Light Tape® Electroluminescent lamp.
- Only one electrical connection required at beginning of profile with no termination connection at other end.
- Aluminum profile length +/-3mm.
- Extremely energy efficient: 1/2 a watt per meter
- Screwed into wall and then hung using rear mount channel.
- End caps as well as corner caps provided for transitions.

System and Parts

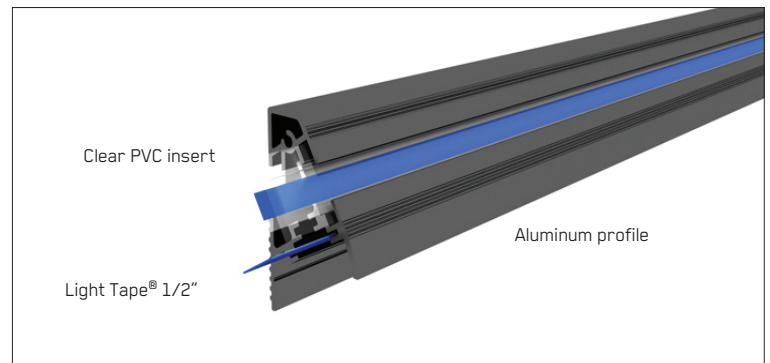

How to Order

- Part Number: SG-WG-HB
- For a basic quote, we need the total length of profile needed per entrance or stairway for us to estimate materials and power.
- We also offer a service where we will go through architectural files to determine layout and what is required for the installation.

Available Colors



- Completely even floor illumination with no glare
- 1/2 a watt per meter of consumption, less than 6 mAmps
- Insert in top location provides additional navigation guidance

Rapid Installation

- Always use Heat Shrink Tubing Thin Wall, 2:1 Shrink Ratio to seal connections between profile lead and your main wiring.
- To fix profile on surface, we recommend using 1/4 x 2 1/4 screw with nylon anchor every 10cms / 3.93 inches.

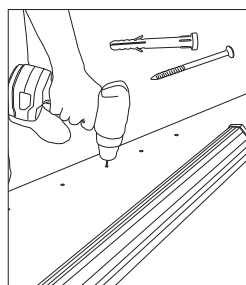
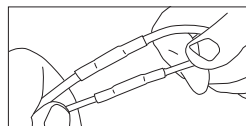

For step by step installation process, please refer to our installation manual guide.

SG-WG-HB Dimensions

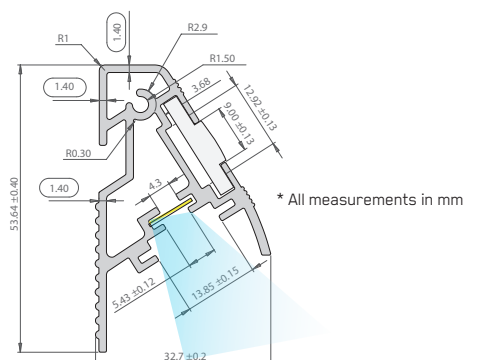

Color Options

Our base colors are Classic Natural Blue and Extreme Blue-Green. These colors appear white when off and colored when illuminated. We then add a filter to produce specific color options. All other colors will remain that color when not illuminated. Please check our website for updated and new colors.

Classic Series

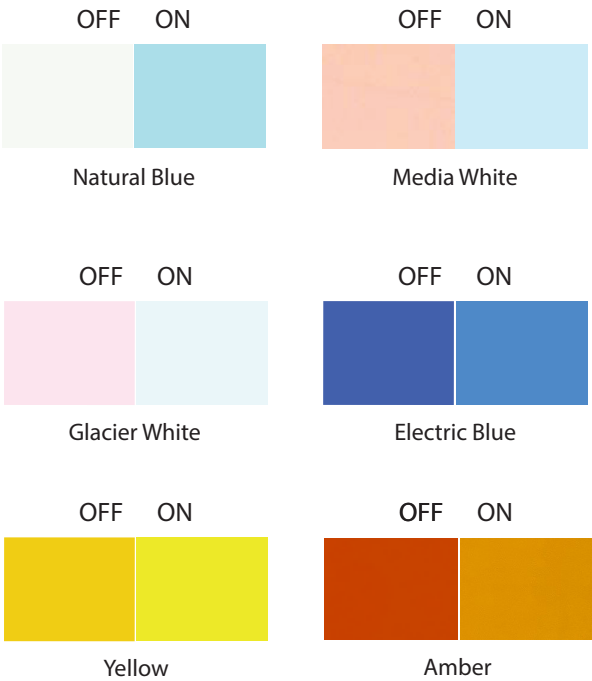

A	B	Inches
6.35mm	19.05mm	0.25

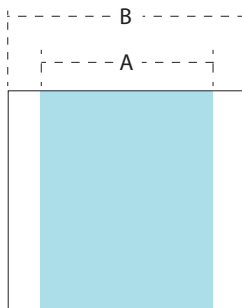

A= Illuminated width
B= Laminated width

Extreme Series

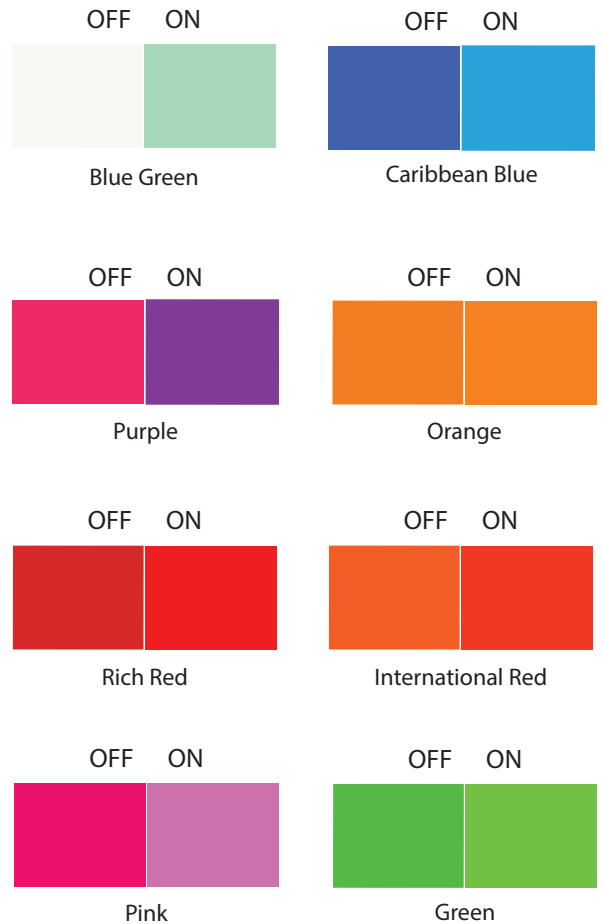

* The colors in this table are simulated and the final product may vary. If an exact color is required, we recommend seeing a physical sample. Custom colors and widths are available, but may be subject to minimum order quantities, set-up fees, and approval testing.

Digital Smart Driver™ Power Supply

Digital Smart Driver™ power supplies are specifically engineered to illuminate Light Tape®. Whether it is one segment or 80, it is possible to do it all with one Smart Driver™. There are a variety of models to choose from offering a variety of useful features. A factory representative will advise which model to use based on the total illuminated area, zones, and location.

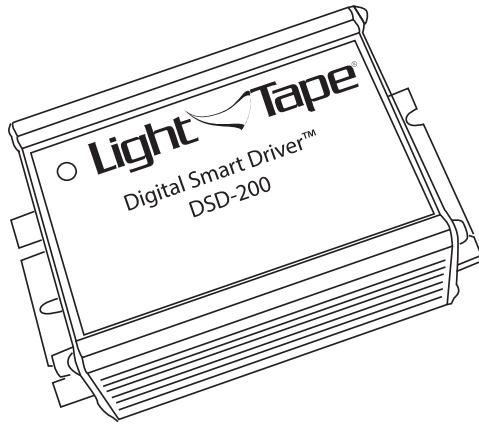

- Quiet
- Stylish compact design
- Rated input voltage 110 / 220 VAC
- Protection Class 1
- IP Degree 2x
- Worldwide voltage capacity
- Blink and Dimmer Switch
- Visual LED system status indicator
- Lightweight
- Short circuit and overload protection
- CE, UL y CSA compliant
- 0-10 dimming

Driver Ranges and Output

Driver Model	Range		Input		Output
	English System	Metric System	Ams	Watts	Max. Current, A
SD-8000	4000 - 8000 in ²	25,806 - 51,612 cm ²	3.50	420	3.8
BUS-DSD-4000	2000 - 4000 in ²	25,806 - 51,612 cm ²	3.50	420	3.8
DMX-DSD-4000	2000 - 4000 in ²	12,903 - 25,806 cm ²	1.5	145	2.1
DMX-DSD-2000	1000 - 2000 in ²	6,451 - 12,903 cm ²	1.0	110	1.2
DMX-DSD-1000	400 - 1000 in ²	2,580 - 6,451 cm ²	0.9	100	1.0
DMX-DSD-200	1 - 200 in ²	6,5 - 1,290 cm ²	0.5	12	0.15
DSD-200 D	1 - 200 in ²	6,5 - 1,290 cm ²	0.5	9	0.15
DSD-2000	1000 - 2000 in ²	6,451 - 12,903 cm ²	2.8	68	0.91
DSD-1000	400 - 1000 in ²	2,580 - 6,451 cm ²	0.9	97	0.32
DSD-400	200 - 400 in ²	1,290 - 2,580 cm ²	0.7	17	0.11
DSD-200	1 - 200 in ²	6,5 - 1,290 cm ²	0.5	9	0.15

*Max Vac is 320v at 750hz

Smart Driver™ Safety & Handling

It is important that you operate Light Tape® and Smart Driver Power Supplies within their parameters. Changes to parameters that result in over current will damage the Light Tape® lamp and power supplies.

- Always attach Light Tape® load before powering .
- 250 volts is mid-range and recommended set point.
- The external dimmer switch on Smart Driver™ controls the output voltage and frequency.
- Use a voltage meter to determine volts /hertz from Smart Driver™ to Light Tape®.
- Always set power supply output voltage per factory recommended setting.
Low: 200 volts | Medium: 250 volts | High: 300 volts
- We DO NOT recommend exceeding 300 volts. Contact us if the Smart Driver™ is operating outside of range.
- Red LED indicates the following :
 - a.Short Circuit Protection : Check wiring if light is on.
 - b.Overload Protection: Verify that lamp area is acceptable, or for possible damage to lamp.
- Always treat Light Tape® and Smart Driver™ with care and respect as one would with any device where electrical current is present
- Please store in appropriate NEMA enclosure for outdoor/damp location.
- Please follow local electrical codes .

Digital Smart Driver™ Power Supply

Features

- StepGuard® is exclusively made for Light Tape®
- DMX Mode- 512 Supplies are fully DMX controllable, allowing for integration into complicated stage and light show.
- Blink Mode- Allows for on/off pulse control with fine turning knob.
- Brightness Control- luminosity adjustment to appropriately match installation environment.
- 0-10 Dimming- Optional function to remotely control Light Tape® brightness using standard 0-10v dimmers. Compatible with Lutron Dimmers.

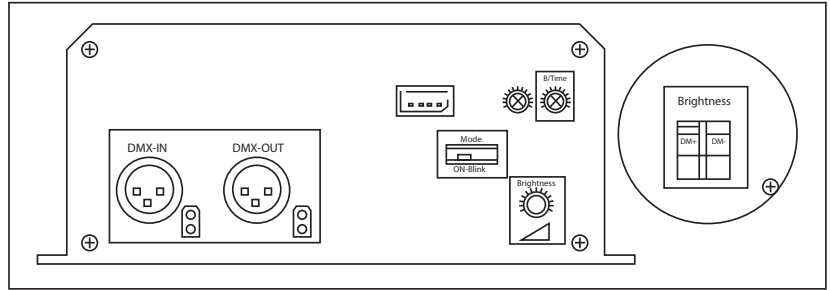

Driver Model	DMX	BLINK	BRIGHTNESS	0-10
SD-8000		X	X	
DSD 200 0-10 DIMMING			X	X
DSD 4000 DMX	X	X	X	X
DSD 1000 DMX	X	X	X	X
DSD 200 DMX	X	X	X	X
DSD 2000			X	X
DSD 1000			X	X
DSD 400			X	X
DSD 200			X	

Power Supply Dimensions

Driver Model	Length		Width		Height		Wheight
SD-8000	9 7/8 in	2.5 cm	4 3/4 in	12 cm	2 1/4 in	5.7 cm	4.15 lb
BUS-DSD 4000	8 3/4 in	22 cm	6 1/4 in	15.8 cm	3 in	7.6 cm	5.15 lb
DMX-DSD 4000	8 6/8 in	22 cm	7 1/4 in	18.5 cm	2 3/4 in	7 cm	4.9 lb
DMX-DSD 2000	8 6/8 in	22 cm	7 1/4 in	18.5 cm	2 3/4 in	7 cm	4.9 lb
DMX-DSD 1000	7 3/4 in	19.5 cm	3 3/8 in	8.5 cm	2 in	5 cm	1.85 lb
DSD 200 DMX	6 in	15.5 cm	2 5/8 in	6.75 cm	1.5 in	4 cm	0.85 lb
DSD 200 D	6 in	15.5 cm	2 5/8 in	6.75 cm	1.5 in	4 cm	0.8 lb
DSD 2000	8 3/8 in	22.5 cm	3 3/8 in	8.5 cm	2 in	5 cm	2.05 lb
DSD 1000	7 3/4 in	19.5 cm	3 3/8 in	8.5 cm	2 in	5 cm	1.85 lb
DSD 400	6 5/8 in	16.5 cm	2 5/8 in	6.75 cm	1.5 in	4 cm	1.05 lb
DSD 200	4 7/16 in	11.3 cm	2 3/4 in	7.0 cm	1 5/8 in	4.1 cm	0.70 lb

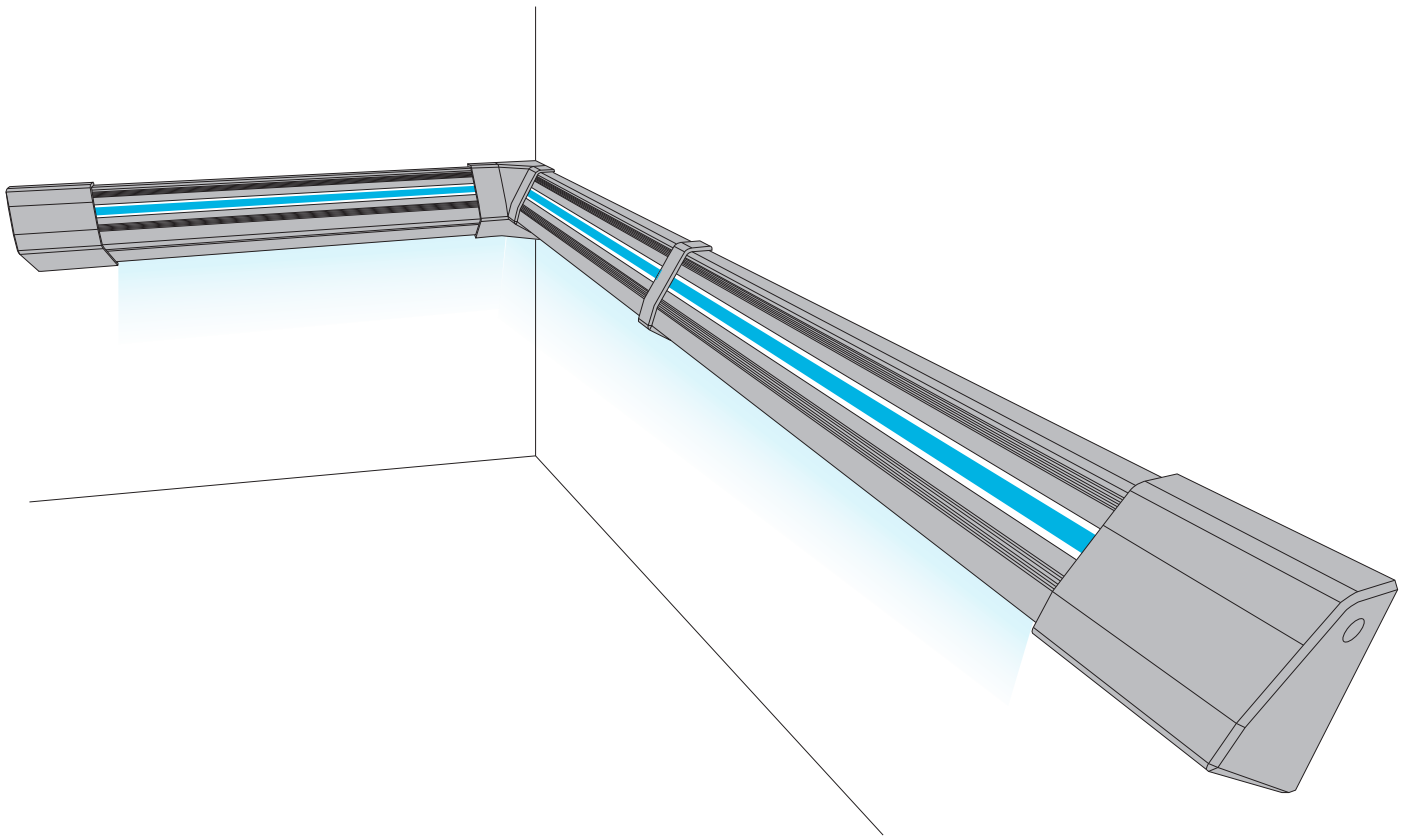

WALL GUIDE
INSTALLATION INFO



The WallGuide(tm) Part description

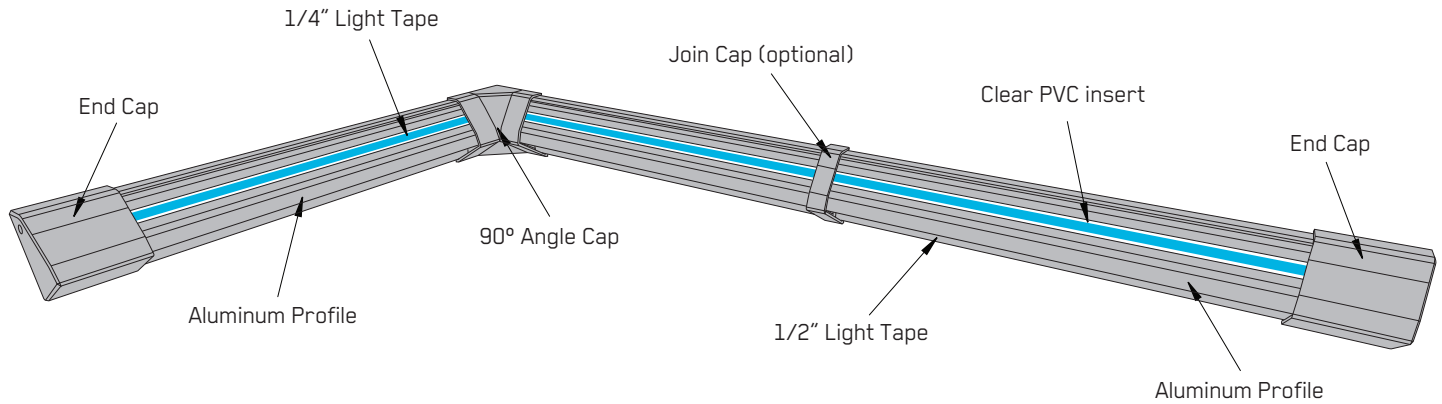

Mounting & Wiring Accesories

End caps

The end caps made of PLA plastic are use to finish the end of a segment. The end caps also hold the connection point on either side. Caps are open on the back, making wiring and connection very easy

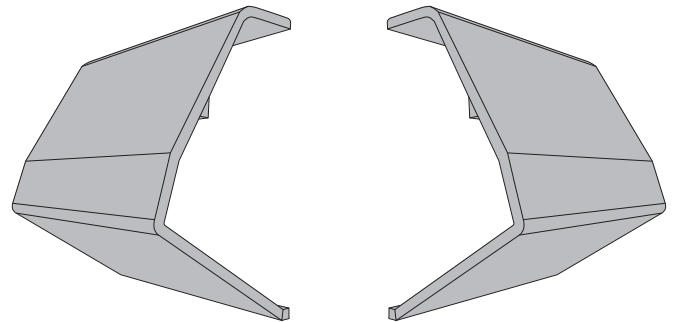

90° angle cap

90 degree angle caps are used as a connection point and to join two segments in a 90 degree inner angle.

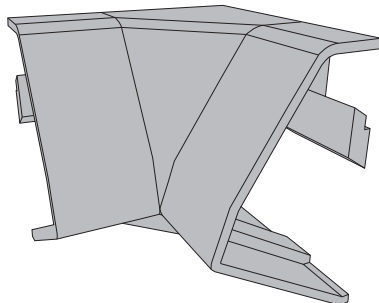

Join cap

Join caps are used to join two segments of the aluminum profiles to hide the edge cuts. Join caps allow light and insert to pass through both segments.

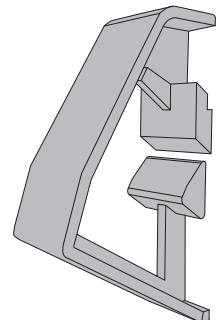

Quick Start Guide

1.

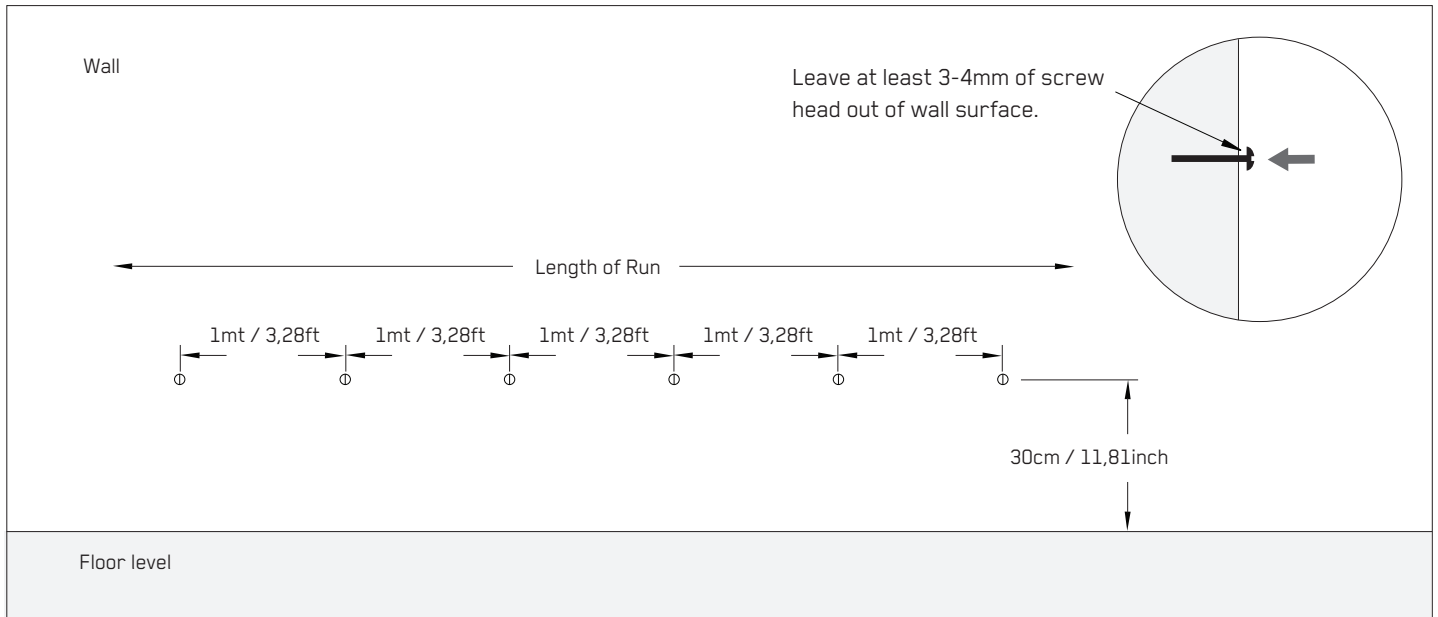

Once length of run is set, mark and drill holes at 30cm/11,81 inch above floor level with a minimum distance of 1 mt / 3,28ft between them, covering the entire length of the run.

2.

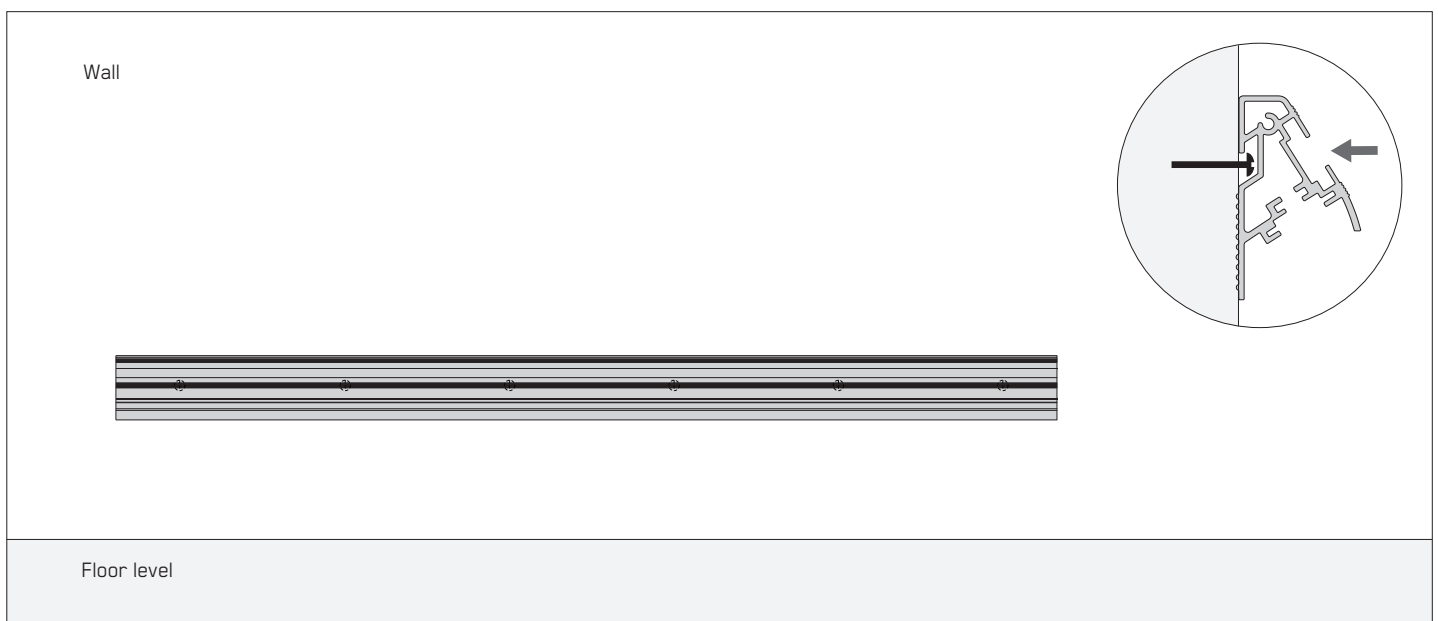

Take the aluminum profile and push it against the wall aligning the screws with the mounting cavity as shown.

Quick Start Guide

3.

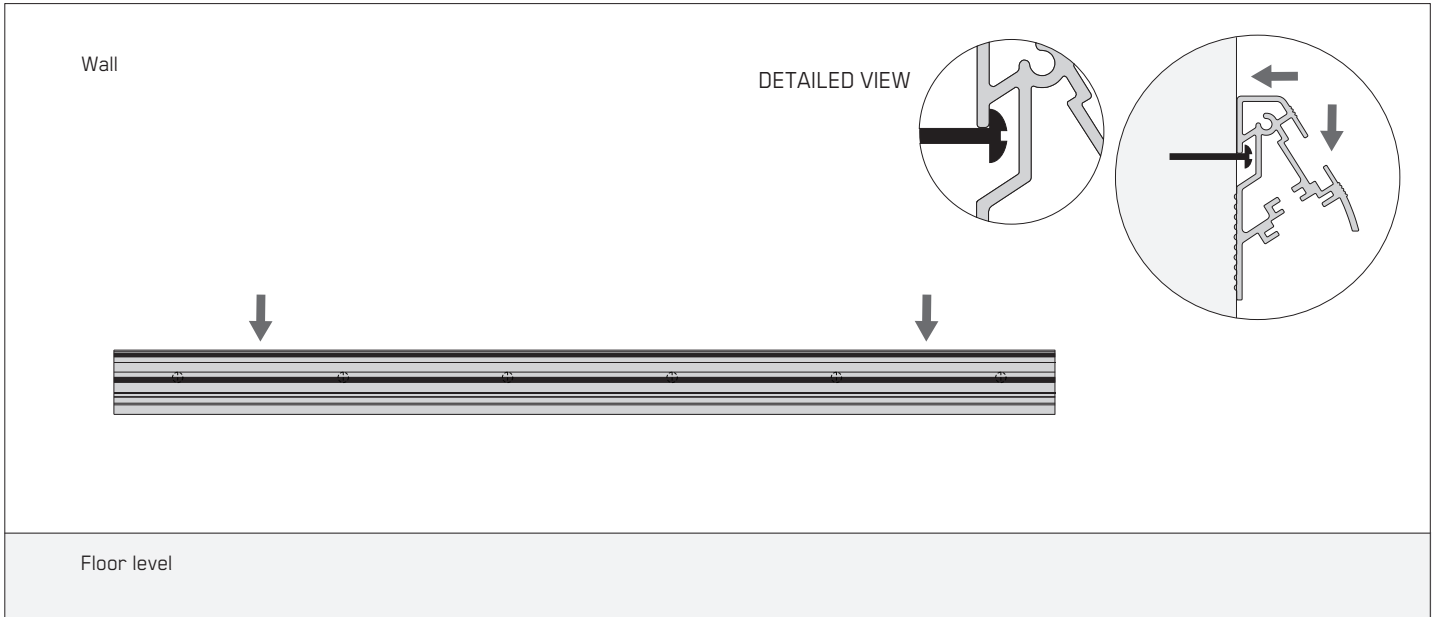

While pushing the profile, pull it down so it will rest on mounting cavity as shown. Push it against you to make sure it is properly resting on screws.

4.

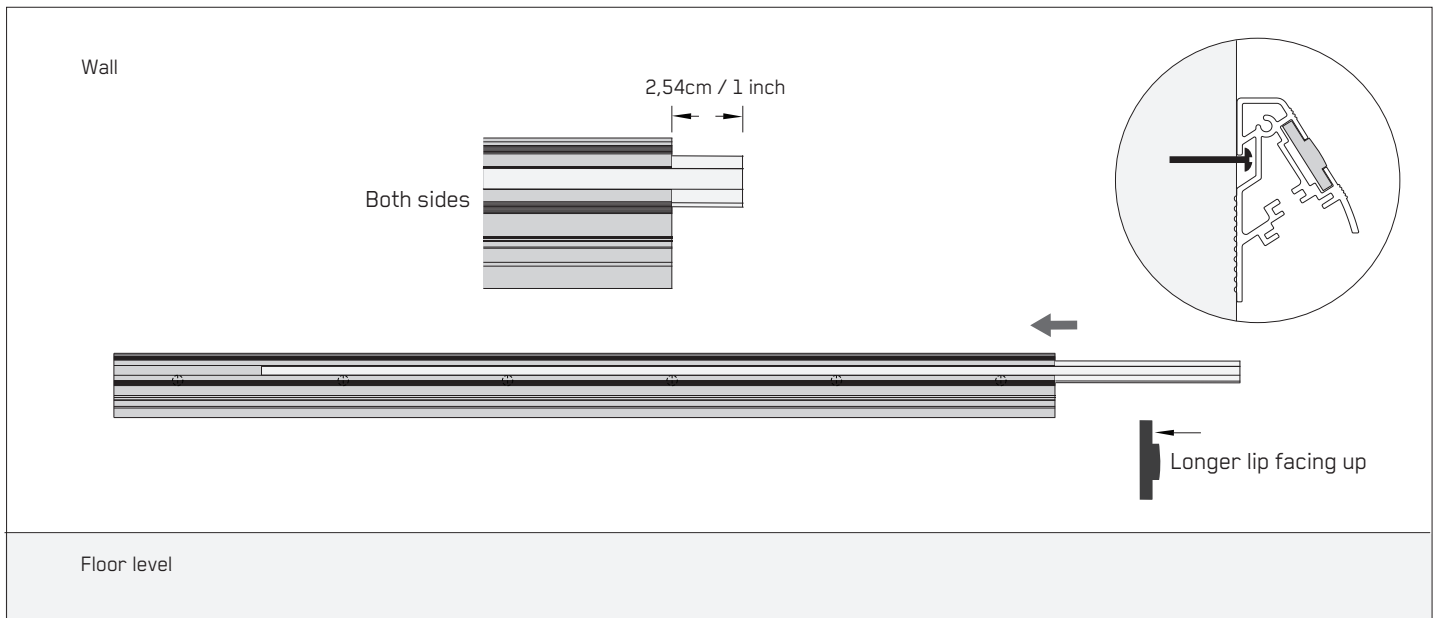

Slide the clear insert on its cavity making sure the longer lip is facing upwards as shown. Cover the entire length of run leaving an additional extra inch out on both sides.

Quick Start Guide

5.

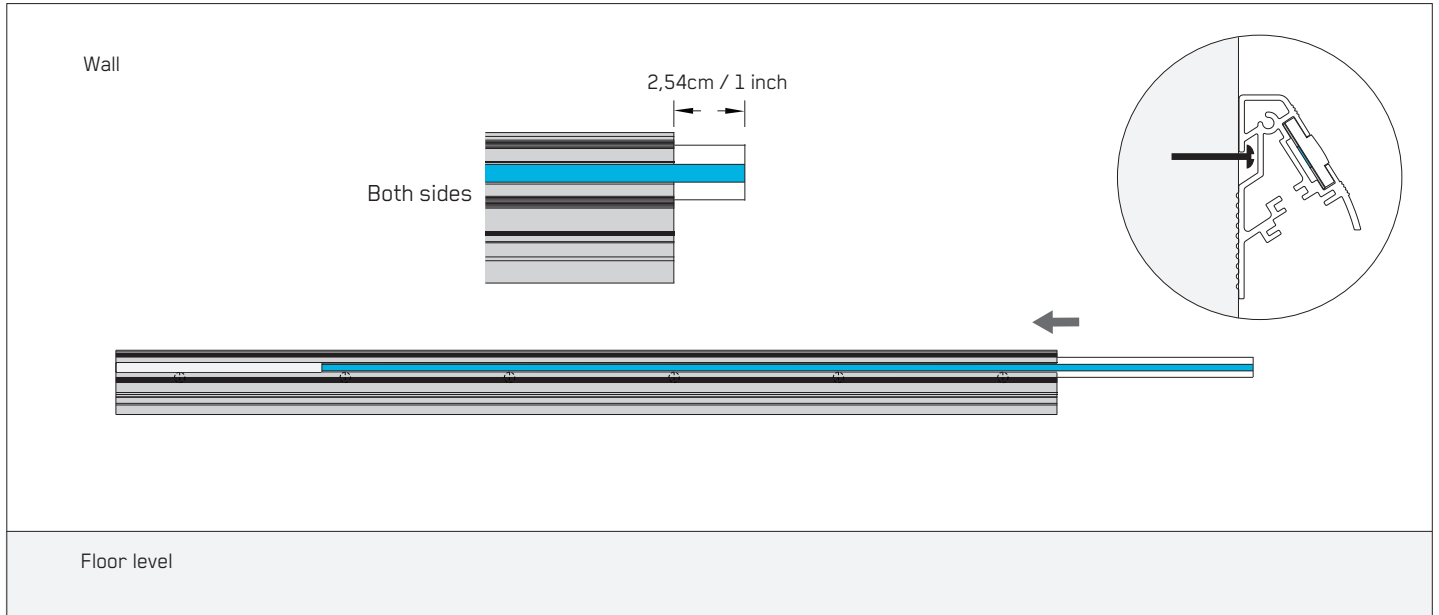

Slide the Light Tape® on its cavity. Cover the entire length of run leaving an additional extra inch out on both sides.

6.

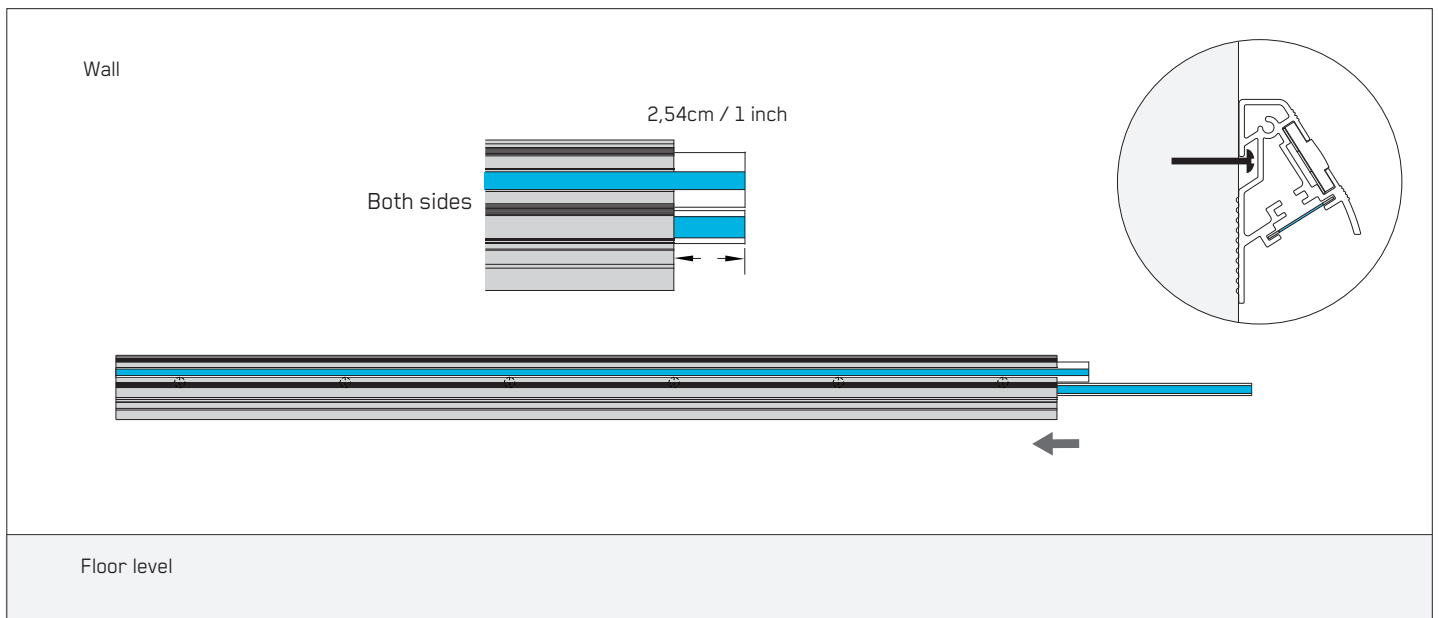

Repeat process for downlight. Cover the entire length of run leaving an additional extra inch out on both sides. Downlight does not use clear protection insert

Quick Start Guide

7.

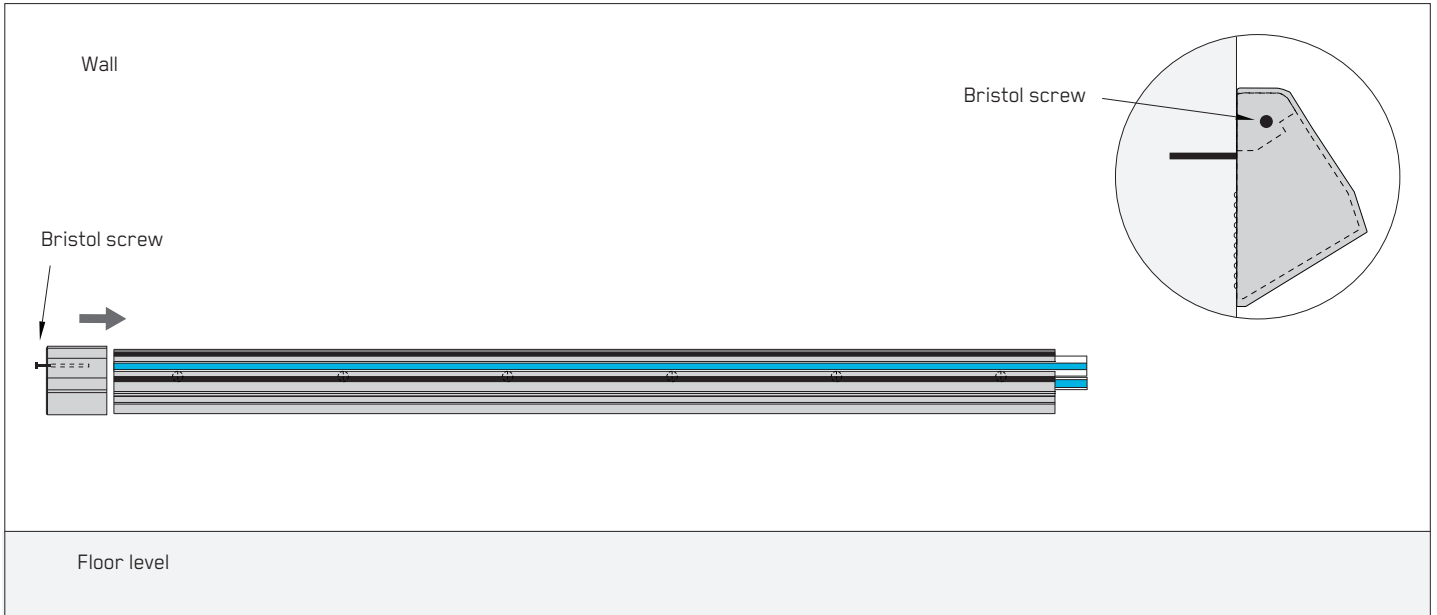

Place the end cap opposite to connection point by sliding it against the profile. Secure with provided bristol screw.

8.

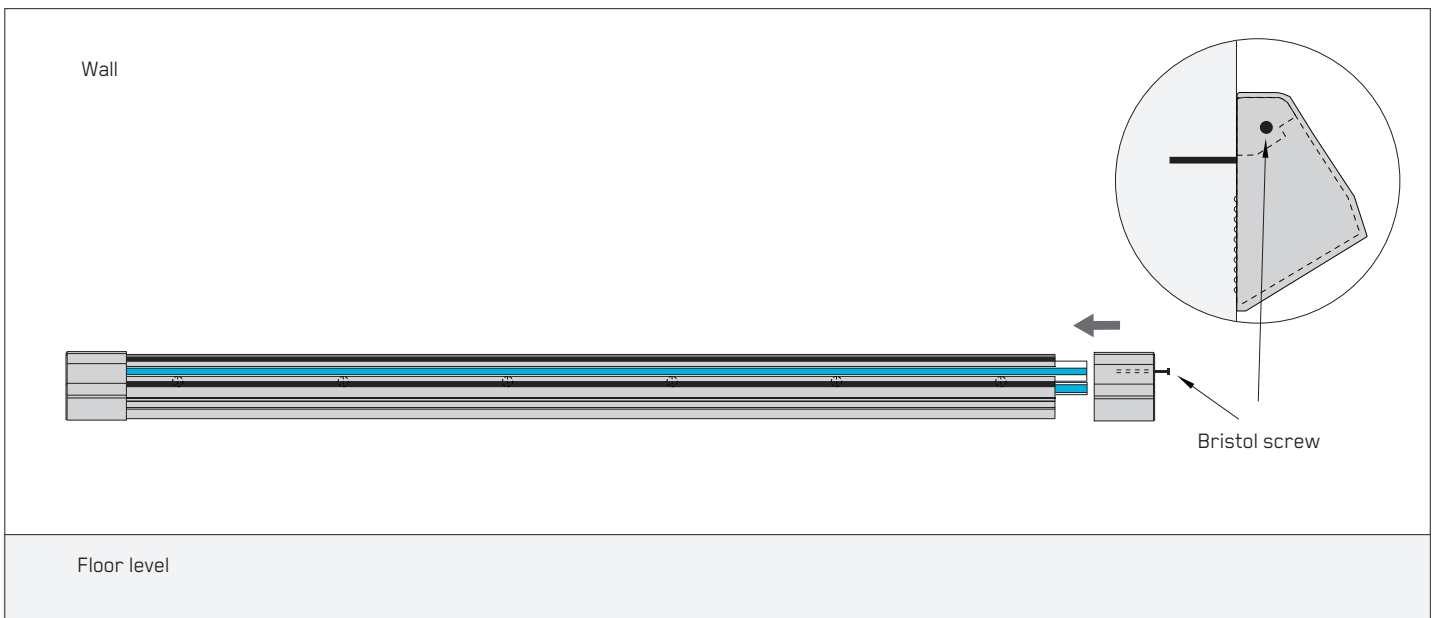

Repeat process on connection point by sliding it end cap against the profile. Be careful with the wires and connector before securing it with provided bristol screw.

Quick Start Guide

9.

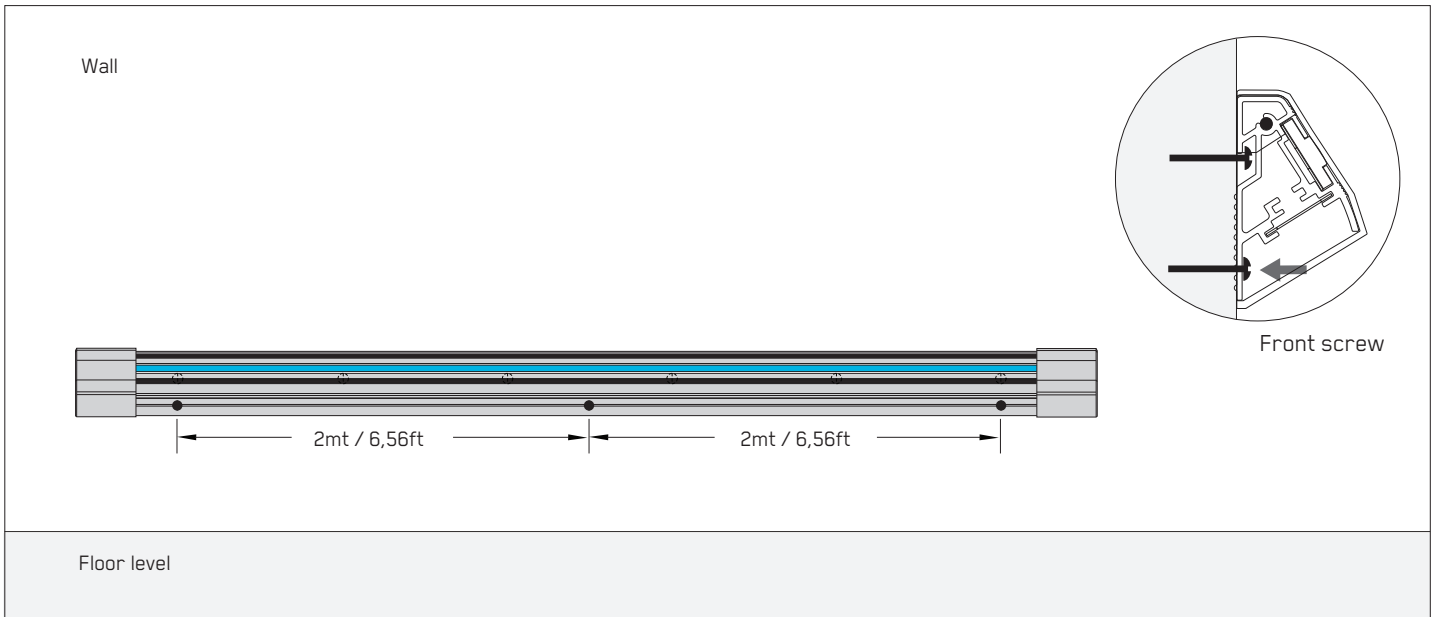

Once system is checked and working, finish the mounting drilling the front screws at least every 2m / 6,56ft from each other.

10.

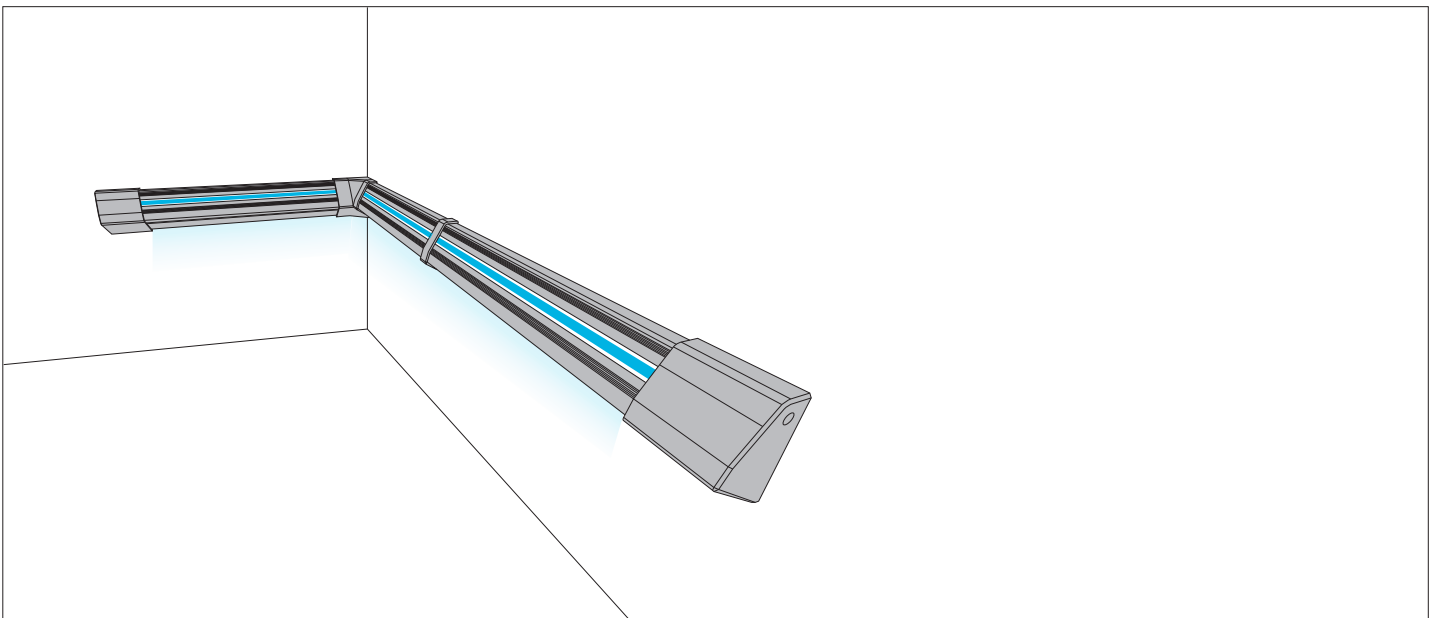

If using angles, repeat process from steps 1 - 9. Placing join caps and angle caps is further explained on this guide.

Wiring options for two segments with 90° angle

Light Tape® Top Connector ————
Light Tape® Bottom Connector ······

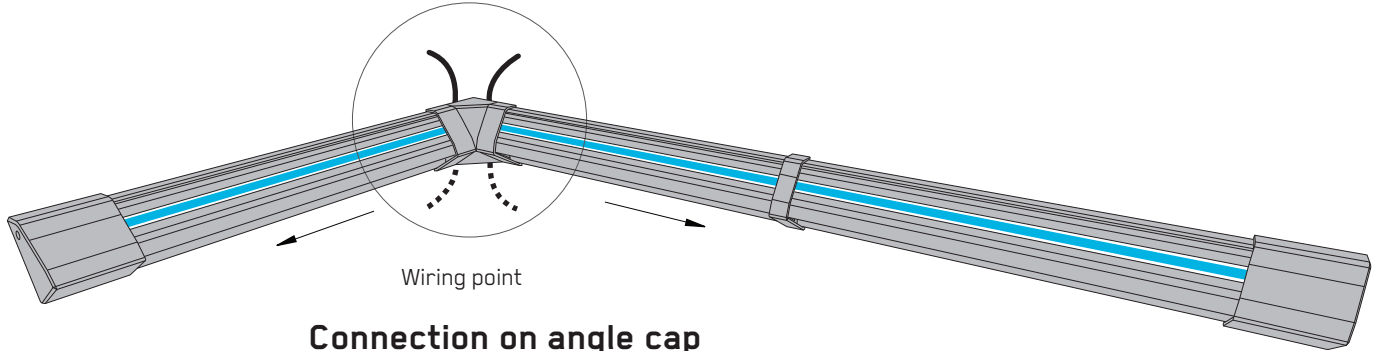

Connection on angle cap

All connections can be located at the angle cap

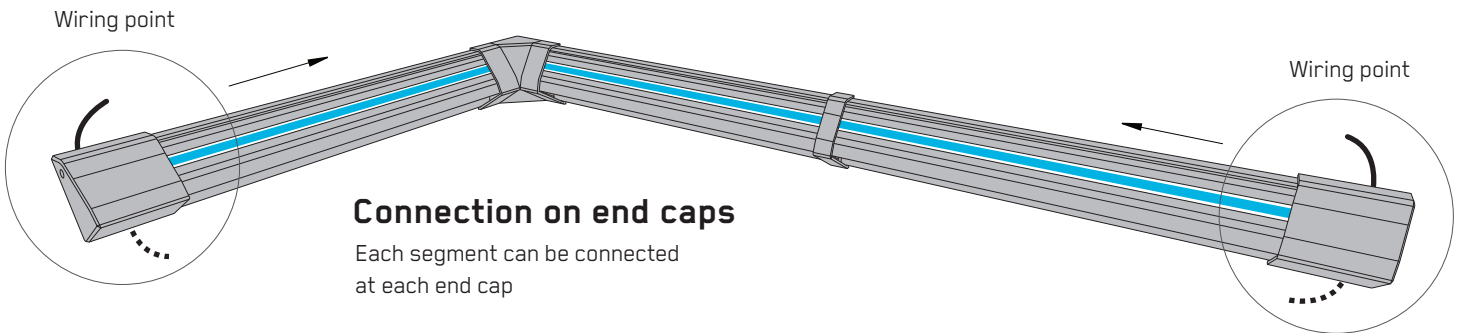

Connection on end caps

Each segment can be connected at each end cap

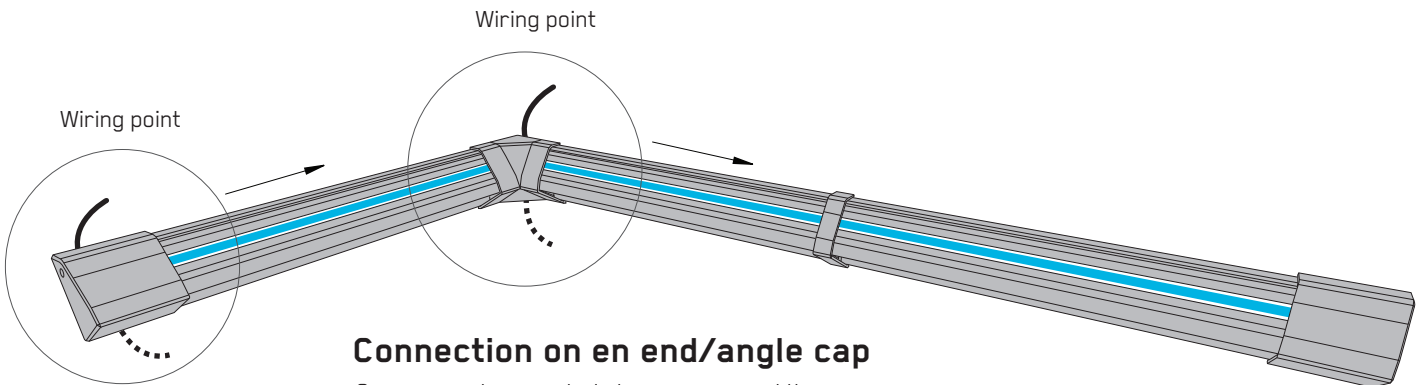

Connection on en end/angle cap

One segment connected at one en cap and the other at the angle cap

Export Packing

Features

- Sturdy Palletized Wooden Crate made of Certified Wood as per International Standard for Phytosanitary Measures (ISPM15 or NIMF15).
- Sealed with screws and secured with plastic bands and two security labels with consecutive numbering or code.
- Every box is stenciled with logos and description of content.
- Interior of crate is protected with kraft paper and bubble wrap for extra protection.
- Every Box is made to size according to customer's order.

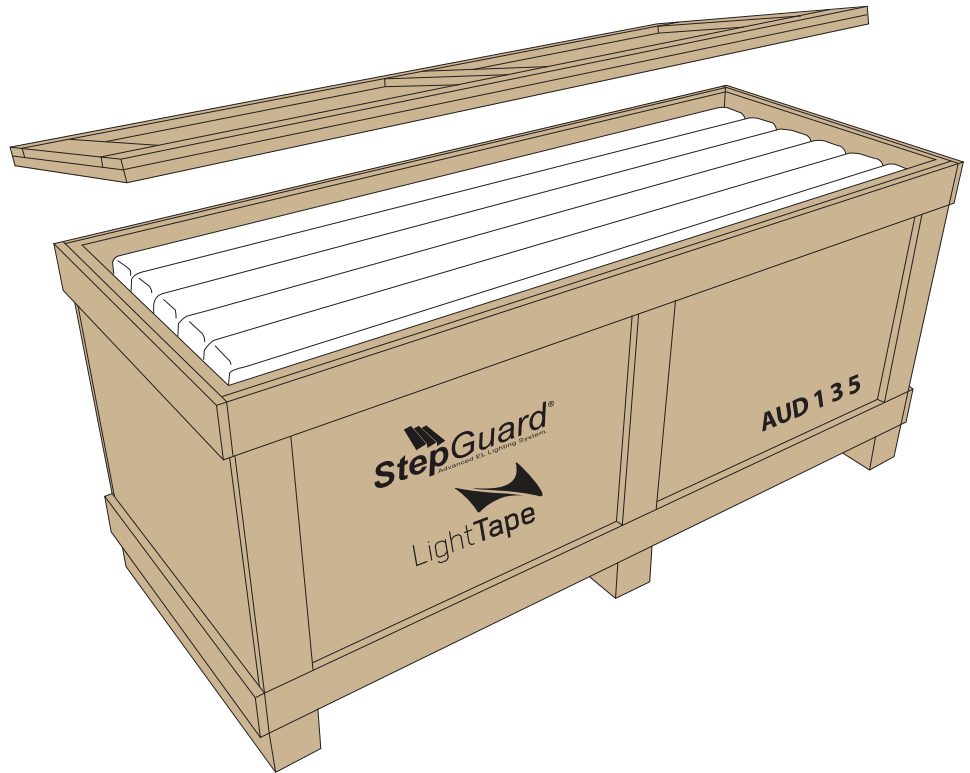

Packing Unit

Units are packed in pairs (as per detail). Box includes also Smart Drivers and spares if requested.

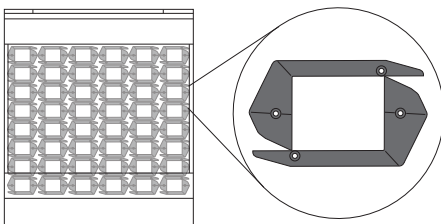

Packing unit
(6 x 10 cms)

Box Dimensions

Height (front view)

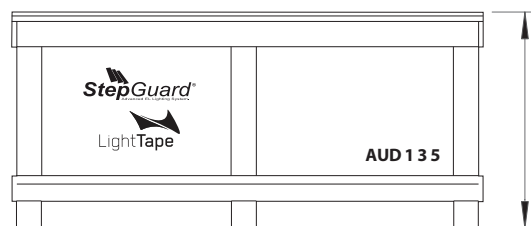

Height of box is calculated by taking the quantity of steps, divided by 12 which is the maximum quantity per row (six pairs). Then adding 6 cms to packing unit and 14cms for the skids and box wall.

Length (top view)

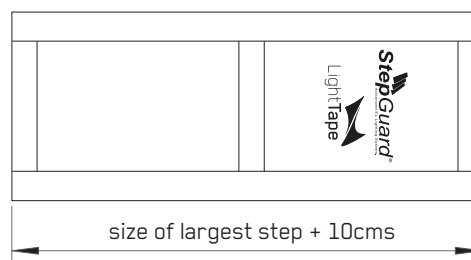

Depth (side view)

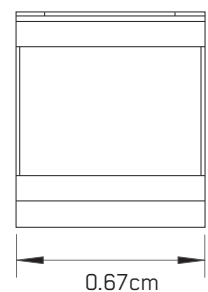

StepGuard Cleaning & Maintenance Information

For external parts of StepGuard™ fixtures

- 4 ABS End Caps**
All end caps must be properly secured to profiles with the screws. Missing, loose or broken end caps should be replaced immediately.
- 5 Bristol Screws (on end caps)**
Both screws should be secured on each end cap. Missing screws or with signs of rust should be replaced immediately
- 6 Light Tape™**
Make sure Light Tape™ lights evenly on its entire length. Lights should not twinkle or blink while on. Light Tape™ should be replaced if signs of humidity, or stains are shown. Please contact Technical Department for more information.
- 7 Wiring**
Inspect that no wires are hanging below fixture. All wiring should be hidden and secure underneath the extrusion.

General Cleaning

A regular cleaning should be performed to prevent the build up of dirt and grease, which could compromise the anti-slip properties and the general appearance of the fixture.

Avoid the use of cleaners containing hydrocarbons, bleach or citrus based agents to clean the StepGuard™ fixtures. You should also avoid the use of steam cleaners, power washers or floor sealants to clean the inserts or end caps.

FOR DAILY CLEANING

Brush down the entire fixture using a soft bristled brush and clean the insert and anti-slip using a damp cloth. Do not soak around the caps or connection or wiring areas.

Aluminum profiles

If heavier marks or sticky stains are seen, clean them using a damp cloth with aluminium safe detergent. Light surface scratches on paint can be removed using a fine wire wool and buffed with a soft cloth. Make sure as much water or cleaning solution is removed as possible.

ABS End Caps / PVC Clear inserts

Only soap and water should be used during ABS cleaning as the use of other chemicals such as chlorides, ketones and degreasers accelerates aging and give them a yellowish color. The cleaning should be done with with a soft cloth or paper. Allow the system to be completely dry.

If you have any doubts or questions regarding product maintenance, please contact our Technical Department at:

Electro-LuminX Lighting Corporation

1320 North Arthur Ashe Boulevard	1.804.355.1692
Richmond, Virginia 23230	+44.7860.967410 GMT
	thelighttapeteam@lighttape.com



StepGuard[®]
Advanced EL Lighting System.

designed for

LightTape[®]

Electro-Luminix Lighting Corporation

1320 North Arthur Ashe Boulevard
Richmond, Virginia 23230

1.804.355.1692
thelighttapeteam@lighttape.com