

StepGuard™ Climax Duo (PN: SG™ CLIMAX DUO)

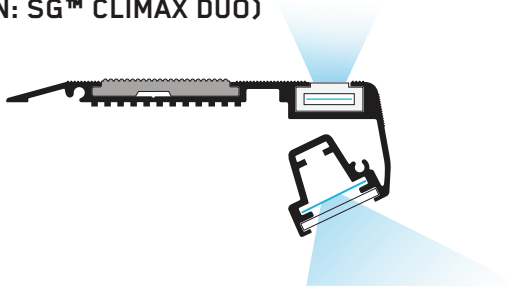

How to Specify: SG™ CLIMAX DUO

- StepGuard™ PN: SG™ CLIMAX DUO with Light Tape® electroluminescent lighting, manufactured by Electro-LuminX Lighting Corporation in the United States.
- For a basic quote, we need the number of steps per cinema and total meters of profile to determine power requirements.
- We also offer a service where we will go through architectural files to determine layout and what is required for the installation.
- For final sign-off we will need the color of Light Tape®, each step length and which side of step for electrical connection.

SG™ Climax Duo: Two Light Tape® Lamps

Our most popular model combines the best features of our Classic and Max designs into the ideal step light, utilizing our proprietary Light Tape® lamps. By focusing illumination at the top edge of each step, it clearly defines the leading edge to help reduce falls and prevent overstepping during descent – all without glare.

The downlight position is based on the immersive Max profile originally designed for IMAX, casting illumination across the landing tread to clearly define the full width of each step. Combined with the illuminated leading edge, the system promotes confident, precise foot placement with every step.

Description of Parts

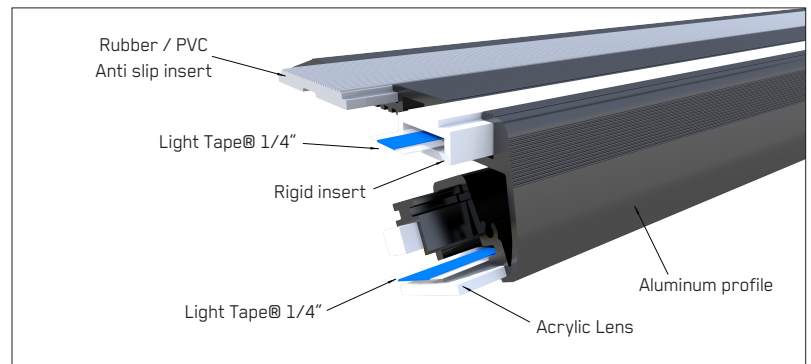

SG™ Climax Duo Design Features

- Arrives Plug & Play ready for installation. IP65 rated.
- Illuminated by Light Tape® Electroluminescent lamps.
- Aluminum profile length tolerance +/- 3mm.
- Extremely energy efficient: 1/4 watt per meter.
- Fully compliant - TUV IECEE IP65 certified.
- Aluminum profile with non-slip insert on top.
- Screws into step for quick installation.
- Mechanically fastened end caps, not glued.



Available Colors



- No glare, completely uniform light with no heat.
- 4 1/4 watt per meter. 10% of LEDs at same brightness.
- Only 3 milliamps of current per linear meter step.

Rapid Installation

- Always use Heat Shrink Tubing Thin Wall, 2:1 Shrink Ratio to seal connections between profile lead and your main wiring.
- To fix profile on surface, we recommend using 1/4 x 2 1/4 screw with nylon anchor every 10cms / 3.93 inches.

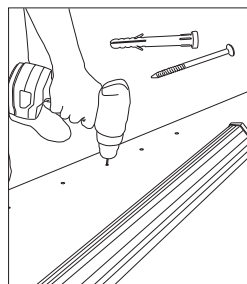
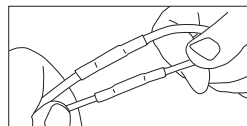

For step by step installation process, please refer to our installation manual section.

General SG™ Climax Duo Dimensions

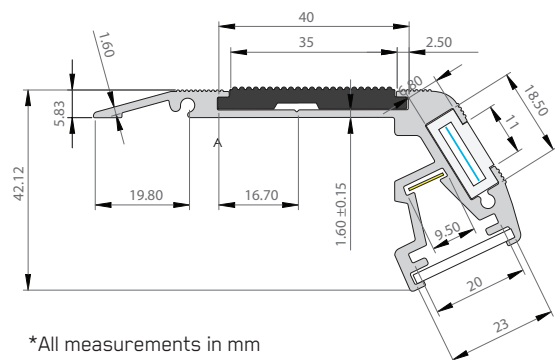

*All measurements in mm