

StepGuard™ Climax Stadium (PN: SG™ CLIMAX STADIUM)

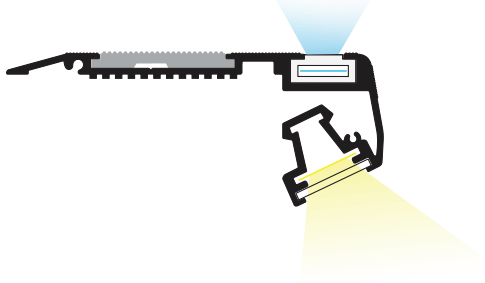

How to Specify: SG™ CLIMAX STADIUM

- StepGuard™ PN: SG™ CLIMAX STADIUM with Light Tape® electroluminescent lighting, manufactured by Electro-LuminX Lighting Corporation in the United States.
- For a basic quote, we need the number of steps per cinema and total meters of profile to determine power requirements.
- We also offer a service where we will go through architectural files to determine layout and what is required for the installation.
- For final sign-off we will need the color of Light Tape®, each step length, and which side of step for electrical connection.

SG™ Climax Stadium: Light Tape® Lamp and LEDs

Ideal for the new stadium staircase designs that many are now incorporating when adding luxury seating. We replace the Light Tape® downlight with a high bright LED, designed to cast light further and cover the wide transition area as you approach the next level of steps.

The downlight LEDs have a shroud to prevent forward lighting on the screen and are dimmable. Depending on width of the transition area, we also offer puck light options to solve the wide landing illumination challenges and preventing glare.

The Climax Stadium is recommended for flat floors or low pile carpet venues. Specifically designed for illuminating large areas with stadium seating.

Description of Parts

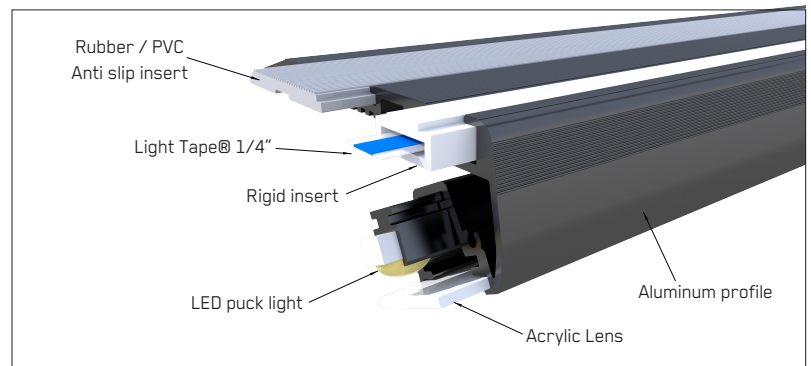

SG™ Climax Stadium Design Features

- Arrives Plug & Play ready for installation. IP65 rated.
- Illuminated by Light Tape® electroluminescent lamps.
- Aluminum profile length tolerance +/- 3mm.
- Extremely energy efficient: 1/4 watt per meter.
- Fully compliant - TUV IECEE IP65 certified.
- Aluminum profile with non-slip insert on top.
- Screws into step for quick installation.
- Mechanically fastened end caps, not glued.



Available Light Tape® Colors



- No glare, completely uniform light with no heat.
- 4 1/4 watt per meter. 10% of LEDs at same brightness.
- Only 3 milliamps of current per linear meter step.

Rapid Installation

- Always use Heat Shrink Tubing Thin Wall, 2:1 Shrink Ratio to seal connections between profile lead and your main wiring.
- To fix profile on surface, we recommend using 1/4 x 2 1/4 screw with nylon anchor every 10cms / 3.93 inches.

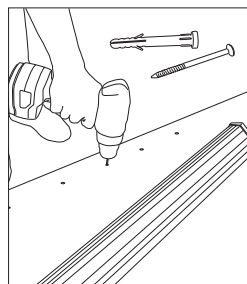
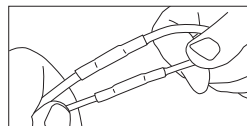

For step by step installation process, please refer to our installation manual section.

General SG™ Climax Stadium Dimensions

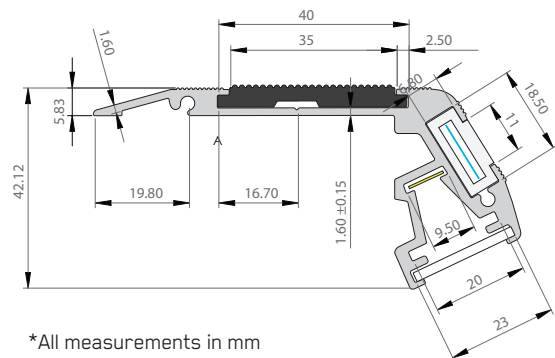

*All measurements in mm